

TELEQUIPMENT
OSCILLOSCOPE
TYPES D52 & S52

All Telequipment instruments are subject to continuous development and improvement, consequently this instrument may incorporate minor changes in detail from the information contained herein.

Telequipment is a registered trade mark of
TELEQUIPMENT LIMITED*
313 Chase Road
Southgate
London, N.14
England.

Telephone: 01-882 1166
Telex: 262004
Cables: TELEQUIPT LONDON N 14

* Member of the Tektronix group

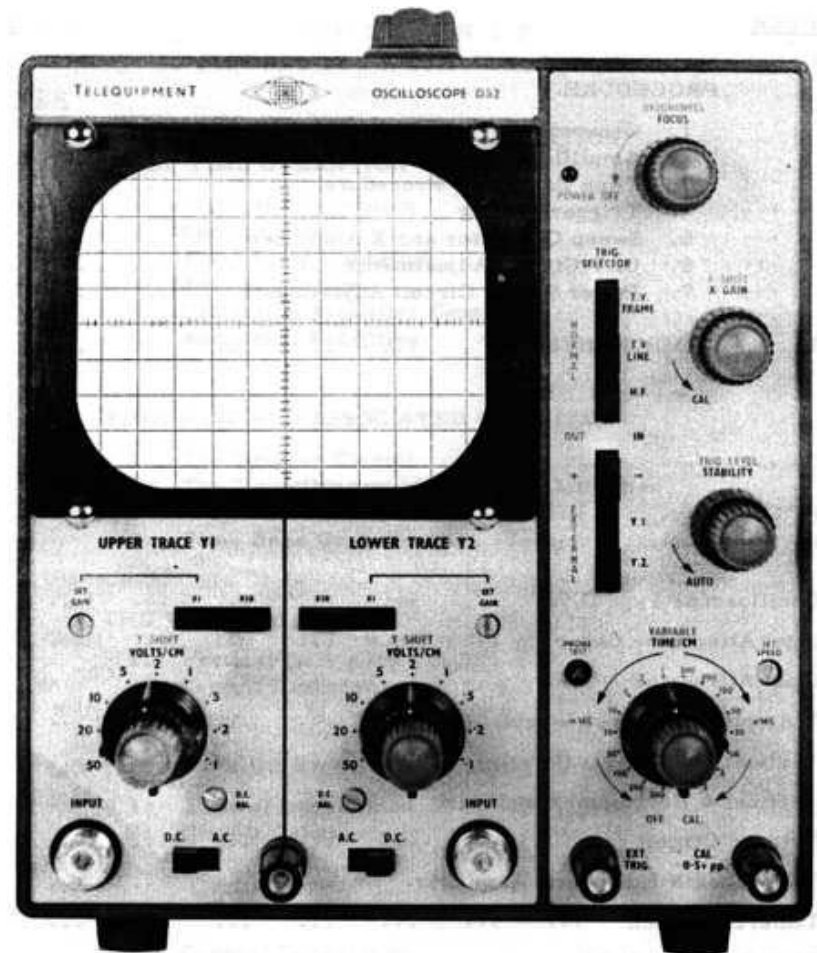

PLATE 1. OSCILLOSCOPE Type D52

CHAPTER 1

GENERAL DESCRIPTION, SPECIFICATION

FIRST TIME OPERATION

1. GENERAL DESCRIPTION

The S52 and D52 Oscilloscopes are two instruments using very similar circuits and components.

The D52 uses a 5" flat faced split beam CRT to provide a dual trace instrument, while the S52 uses a 5" flat faced single beam CRT with identical vertical and horizontal deflection amplifiers to provide a large display X-Y oscilloscope.

Both instruments use a common time base and power supply. The following details apply to both instruments, any differences between them being separately described.

2. SPECIFICATION

2.1 Vertical Deflection Amplifier

Each consists of a four stage, balanced, DC coupled amplifier, compensated for optimum pulse response and having no overshoot.

2.1.1 Frequency Response & Sensitivities

D 52	(DC - 6 MHz at 100 mV/cm
	(DC - 1 MHz at 10 mV/cm
S 52	(DC - 3 MHz at 100 mV/cm
	(DC - 1 MHz at 10 mV/cm

2.2 The Timebase and Horizontal Deflection Amplifier

Has eighteen preset calibrated sweep speeds:
500, 200, 100, 50, 20, 10, 5, 2, 1 milliseconds per cm.
500, 200, 100, 50, 20, 10, 5, 2, 1 microseconds per cm.

All the above are at minimum "X" expansion.

A VARIABLE control covers intermediate speeds.

The time measurement accuracy is $\pm 5\%$.

The sweep generator is a Miller circuit, giving excellent linearity. The Horizontal Deflection Amplifier X GAIN control permits the trace to be expanded to approx. 10 screen diameters. Sufficient shift is provided to enable any part of the expanded trace to be positioned centrally on the screen.

Terminal sockets on the rear panel enable:

(a) an external timebase waveform to be applied in which case the internal timebase should be switched off.

(b) the internal timebase waveform to be used for external purposes.

2.3 Triggering

Two modes of triggering are provided:

(1) Auto. On this setting the sweep free runs at a slow speed in the absence of an input signal, but is triggered automatically as soon as an input signal is applied.

(2) Trigger Level Selection. With the AUTO switch off, the TRIG LEVEL control allows the sweep to be triggered from any part of the slope of the input waveform.

2.4 Trigger Selection

Selector switches enable the timebase to be triggered from the output of either Deflection Amplifier, positive or negative; or from an external input, positive or negative.

2.4.1 H.F. Triggering

A special H.F. switch position gives good synchronization from high frequency input signals between 1 MHz and 10 MHz.

2.4.2 TV Sync.

D.c. restoration enables the sweep to be triggered from the LINE or FRAME pulses of a composite TV waveform without a change of picture content affecting the triggering point.

2.5 Calibration Waveform

A 0.5 volt peak to peak square wave, at mains supply line frequency and stabilized against line voltage variations, is available at a connector on the front panel for calibration purposes.

2.6 Trace Unblanking

A d.c.-coupled flyback suppression system ensures uniform trace brightness at slow sweep speeds and complete suppression of the timebase flyback.

2.7 Z-MOD Socket

A connector on the rear of the instrument permits intensity modulation of the beam for accurate measurement of rise times, etc.

2.8 Valve and Semiconductor Content

<u>Qty</u>	<u>Type</u>	<u>Qty</u>	<u>Type</u>
1	ACY 22 Transistor	1	EB 91
4	2N3702 Transistors	1	E 13-12 or 55451 CRT (D 52)
10	ECC 88	1	D 13-30 CRT (S 52)
4	ECF 80		

2.9 Supply Voltage and Current

(1)	100 - 125 V)	-	at 50-60 Hz
(2)	200 - 250 V)		

Power consumption 90 VA.

2.10 Cooling

The instrument is cooled by convection. Air enters the bottom of the case and is drawn up past the tubes and other hot components, passing out through slots at the top. The air flow must not be obstructed in any way.

2.11 Dimensions

8½" wide x 9.3/16" high x 15" long
(21 cm x 23 cm x 38 cm)
Weight: 24 lbs (11 kg)

3. FIRST TIME OPERATION

3.1 Introduction

The following detailed instructions are intended for those unfamiliar with this type of oscilloscope. It is suggested that the user should carefully carry out this procedure several times, in order to become thoroughly familiar with the instrument before putting it into use.

External controls are shown in CAPITALS underlined; internal presets are indicated in CAPITALS only.

3.2 Connection to Supply

Before connecting the instrument to the supply, check that the voltage selector plug is inserted with its pointer indicating the local supply voltage and that the rating of the fuse fitted is 1A for 200-250V operation or 2A for 100-125V.

The supply lead is alternatively colour-coded as follows:-

LINE	Brown	Red	Black
NEUTRAL	Blue	Black	White
EARTH	Green & yellow	Green	Green

3.3 Operation

Set controls as follows:

<u>BRIGHTNESS</u>	Fully anti-clockwise - switched to OFF
<u>FOCUS</u>	Central
<u>TRIG SELECTOR</u>	Y1 in (D52) or INT in (S52) All other buttons out
<u>X SHIFT</u>	Central
<u>X GAIN</u>	Fully anti-clockwise - CAL
<u>TRIG LEVEL</u>	Fully anti-clockwise - switched to AUTO
<u>STABILITY</u>	Fully clockwise
<u>TIME/CM</u>	5 mSEC
<u>VARIABLE</u>	Fully clockwise - CAL
<u>GAIN</u>	x1 buttons in
<u>VOLTS/CM</u>	0.2

<u>SHIFT</u>	Central
<u>DC/AC</u>	DC
<u>INT TB/X-Y</u>	INT TB - at rear S52 only.

Link both inputs to CAL 0.5Vp-p.

Plug-in to the supply and switch on by the BRIGHTNESS control.

Allow half a minute for the instrument to warm up then turn BRIGHTNESS clockwise for a display of convenient intensity.

Position traces (or trace S52) with shift controls then turn STABILITY anti-clockwise to lock the display. STABILITY should always be set as far anti-clockwise as possible consistent with a triggered display.

Adjust FOCUS for best definition. Occasional readjustment of the internal preset ASTIG control may be necessary to enable FOCUS to bring the whole display into sharp definition.

The display thus obtained will enable the user to gain familiarity with the functions of the various controls.

3.4 X-Y Operation (S52 Only)

Apply the calibrator squarewave to both inputs and set all controls as above. Switch the rear slide switch to X-Y. A straight line trace at 45° to the horizontal will be produced.

3.5 Amplifier Gain and d.c. Balance Adjustment

Refer to pages 26 and 27 of the manual.

3.6 Sweep Speed Calibration

The calibration waveform is at supply-line frequency, so that when the instrument is operated on a 50Hz supply, 1 cycle occupies 20 milliseconds. With the TIME/CM switch set to 10 mSEC and the

VARIABLE control fully clockwise, the timebase speed is 10 milliseconds per centimetre, so that one cycle should occupy two centimetres. The SET SPEED control, adjacent to the TIME/CM switch, is used to adjust the sweep speed on this calibration waveform to give precisely 1 cycle in 2 cm. This standardizes the whole of the time calibration of the instrument, all other ranges being direct multiples of this. Speed calibrations only apply when the VARIABLE control is in the fully clockwise position. On 60 Hz mains the SET SPEED should be adjusted on 10 mSEC/CM so that three cycles occupy 5 cm.

For most purposes, when accurate time calibration is not required, the above controls are used to produce a picture of convenient size, with the TIME/CM switch as the coarse control and the VARIABLE control for fine adjustments.

4. SWEEP CONTROLS

4.1 Trig Level

The Trigger Level control is used to set the precise part of the slope of the input waveform at which the sweep is triggered. The use of this control may be demonstrated as follows:

Set the TIME/CM switch to 5 mSEC, as described in Chapter 2, to give one cycle of the square wave, 4 cm long. Now rotate the TRIG LEVEL control. It will be found that the starting point of the trace can be moved up and down the sloping edge of the square wave. If the control is turned too far clockwise, this point rises above the top of the square wave and the sweep stops. Similarly, rotation too far anticlockwise produces the same effect.

This facility is useful for displaying complex waveforms, when a normal type of sweep generator will either fail to trigger the sweep or cause double trigger action, producing a multiple pattern. It may also be used as an amplitude discriminator, so that signals of small amplitude are ignored and the sweep is triggered only when the input voltage reaches a predetermined value. Positive or negative going edges may be selected by using the TRIG SELECTOR switch.

Adjustment of the sweep speed controls does not shift the starting point of the sweep but expands the trace from this point. Thus it is possible to examine a section of the waveform in detail by setting the TRIG LEVEL control so that the sweep is triggered just in advance of the portion to be examined and then expanding this portion as required by means of the sweep speed control(s).

4.2 Auto

On this setting no control over the trigger level is available; the sweep automatically adjusts itself to trigger at the mean level of the input waveform. This setting may be used for almost all applications involving repetitive waveforms of a simple nature. The sweep generator will be automatically triggered by signals between about 50 Hz and 1 MHz. In the H.F. position the sweep generator will synchronize to incoming signals up to at least 10 MHz provided their amplitude gives about 2 millimetres vertical deflection.

In the "AUTO" position with no input signal the trace will become progressively fainter as the sweep speed is increased. This is due to the sweep running free at about 40 Hz in the absence of a trigger signal, regardless of the setting of the speed controls. As soon as an input signal is applied, the sweep is immediately synchronized by it and the trace reverts to its full brightness.

4.3 Trig Selector

The Trigger Selector switch is divided into two sets of three push buttons. One position, used for most purposes, selects "NORMAL" triggering. The top two buttons bring the d.c. restoration into circuit. This enables the sweep to be triggered from the Line or Frame pulses of a TV waveform (normally negative going) independent of the picture content (positive going). The third button selects H.F. operation. In this latter position the sweep is synchronized by the incoming signals. The lower three push-buttons select positive or negative, Y1, Y2, or external triggering waveforms as required.

A differentiating circuit of 40 μ s is used in the Sync. Separator to permit triggering from the Frame pulse, effectively removing the line pulse.

For triggering from an external signal (minimum .5 volt), set the switch to EXT, and connect the signal to the EXT TRIG terminal socket.

4.4 X Gain and Shift

The X GAIN control expands or contracts the length of the trace from approximately one screen diameter in the anticlockwise position to approx. 10 screen diameters when rotated fully clockwise.

The X SHIFT control is used to centre the trace symmetrically about the ruled graticule or to display any portion of the expanded trace on the screen for examination.

The time calibration holds good only at the minimum setting of the X GAIN control. It is possible to measure time intervals at other settings, however, by using the internal calibration waveform as a standard. For instance, if the X GAIN control is adjusted so that one cycle of the calibration waveform occupies 5 centimetres on the 20 mSEC/CM range, then the gain is exactly five times on all ranges and, provided the X GAIN control is not touched, all sweep speeds will be multiplied by a factor of 5. Any multiplication factor between 1 and approximately 10 is possible.

5. DEFLECTION AMPLIFIER CONTROLS

5.1 VOLTS/CM Switch

This nine-position switch inserts a series of frequency compensated attenuators between the coaxial INPUT socket and the Vertical Deflection Amplifier. If the gain of the amplifier is calibrated, direct readings of input voltages may be obtained. A preset control, adjacent to the Y GAIN switch, enables the gain to be standardized at switch setting "X1". With the Y GAIN switch set to X1 the .5 volt calibration squarewave should measure 5 centimetres vertically with the VOLTS/CM switch set to .1. In the X10 position, the squarewave will occupy 5 cm on the 1 V/cm range.

5.2 X1/X10 Y GAIN Switch

This switch changes the gain of the Y amplifier, the normal (X1) sensitivity being multiplied by 10 when the X10 position is selected. The positions of the attenuator (VOLTS/CM) switch apply only for normal operation and should be divided by ten in the X10 position.

When the amplifier is first switched on, and the X10 gain position is selected, the trace may disappear off the screen and the Y SHIFT range be insufficient to bring it back.

Allow the instrument about five minutes to warm up, and if the trace does not return, re-adjust the bal. control until the trace is central. The DC BAL. control should be set so that there is no trace movement when switching between the X1 and X10 Gain positions.

5.3 DC/AC Switch

This switch will normally be used in the AC position, in which a blocking capacitor removes the d.c. component of the input signal to the Vertical Deflection Amplifier. The time constant of the input circuit in this position is such that the response is 3 dB down at 2 Hz which, whilst adequate for most normal purposes, may prove critical in some applications. (For example, in the AC position, the 50 Hz calibration waveform acquires a pronounced tilt.) If a longer time constant is required, an external blocking capacitor must be used, with a value suitably greater than 0.1 microfarad and the input switch set to DC.

The "DC" position is also used if it is specifically desired to include the d.c. component of the input waveform to be measured.

6. ADDITIONAL FACILITIES

6.1 Sweep Output

The terminal socket marked SWEEP OUTPUT at the rear of the instrument provides a positive going sawtooth waveform of approximately 50 volts maximum amplitude, from the cathode of V106A. This

valve acting as a cathode follower presents a low impedance in its cathode circuit, thus preserving the purity of the waveform. When an external circuit is being driven from this source the STABILITY control must be turned clockwise until the sweep, as displayed on the oscilloscope, runs free.

6.2 X AMP Input

This terminal socket at the rear of the instrument is connected, via a series capacitor (C119) of 0.1 microfarad, to the input of the Sweep Amplifier. It will accept signals between 1 volt and 25 volts peak to peak, and the X GAIN control may be used to give up to 10 times gain.

When using this facility, the timebase must be turned off by turning the VARIABLE control fully anticlockwise to operate the switch ganged to it.

The input impedance is approximately 160 k Ω shunted by 30 pF. The frequency response is 3 dB down at 10 Hz and at about 400 kHz.

6.3 Z MOD

This connector, at the rear of the instrument, is taken, via a blocking capacitor, to one grid of the CRT. A positive pulse applied here will brighten the trace, permitting squarewave rise times to be measured. The time constant of this circuit is formed by 0.01 microfarad and 1 megohm.

6.4 Probe Test

A socket is provided on the front panel to adjust the input capacity of a high impedance probe.

To adjust the probe, set the T/cm switch to 1 mSEC/CM and the V/cm switch to .1 VOLTS/CM on the X1 gain setting, a.c. coupled. Connect the probe output plug to the amplifier input and touch the probe tip on the probe test socket. A vertical edge will be seen, followed by a flat top. Adjust the trimmer capacitor in the probe body, such that the corner of the pulse is square.

TIME BASE AND ASSOCIATED CIRCUITS

1. THE TRIGGER CIRCUIT

1.1 General

Figure 2.1 shows the trigger and TV sync. selection. The operation of the push button switches is described and a detailed summary of the switch positions is also given in this chapter.

1.2 Circuit Description

The trigger amplifier consists of a longtailed pair followed by a cathode follower. The trigger signal from Y1, Y2 or external is selected by S101B and S101C and fed to either grid of the long tailed pair. S101A, (+, -) reverses the connections to the grids. The output d.c. level of the trigger amplifier is varied by RV108, the TRIG LEVEL control which varies the d.c. level of both input grids symmetrically, allowing the triggering point to be set to any desired point on the waveform. On the Auto position the LEVEL control is switched out of circuit and the output of the trigger amplifier is a.c. coupled to the Schmitt trigger circuit. The input grid resistor R118 is returned to the opposite grid causing the circuit to free run at approx. 40 Hz in the absence of triggering signal. As soon as a trigger signal is applied the circuit is synchronised and the time base will trigger from a point near the mean level of the trigger waveform. This setting may be used for almost all applications involving repetitive waveform with approximately equal excursions about the mean level and repetition frequencies between 50 Hz and 1 MHz.

1.3 H.F. Operation

On H.F. operation S102C removes the d.c. coupling between the cathodes of the Schmitt trigger converting it into a multivibrator

running at approx. 0.5 MHz. The circuit will then synchronise to high frequencies from approx. 1 to 10 MHz.

1.4 TV Sync. Pulse Selection

On TV FRAME and TV LINE positions the gain of the trigger amplifier is increased 3 times and a d.c. restoring circuit C106, R118 and MR101 introduced into the Schmitt trigger circuit input. The TRIG LEVEL control is set to trigger off the synchronising pulses. The d.c. restoration prevents change of triggering point with picture content variations. On TV LINE the output of the Schmitt trigger circuit is differentiated by a short time constant C111 and R129 and fed to the timebase. On TV FRAME the time constant is increased by the addition of R133. This gives a greater output from the wider frame pulses than from the line pulses and the time base can be adjusted to trigger off the frame pulses by means of the STABILITY control.

1.5 Trigger Sensitivity

The trigger sensitivity control RV124 is a preset resistor between the cathodes of V103 and is set to give the maximum trigger sensitivity on the 'Cal' waveform without multi-triggering.

1.6 Facilities

The trigger selector switch is divided into two sections, each of which is operated by three push buttons. The functions of the sections are as follows:

<u>Upper Section:</u>	selects NORMAL operation, H.F. operation, or TV sync., line or frame.
<u>Lower Section:</u>	selects the polarity of the triggering signal (positive or negative) and selects the source of the triggering signal (internal Y1 or Y2: external).

In order to clarify the operation of the selector switches, their positions are summarized below:

<u>Switch</u>	<u>Positions of Buttons</u>	<u>D 52 Function</u>	<u>S 52 Function</u>
Upper Section	All Out	Normal	Normal
	Top In	TV Frame	TV Frame
	Middle In	TV Line	TV Line
	Lower In	H.F.	H.F.
Lower Section	Top In	- ve	- ve
	Top Out	+ ve	+ ve
	Middle In	Y1	INT.
	Lower In	Y2	EXT.
	Both Out	EXT.	-

2. THE TIME BASE AND HORIZONTAL DEFLECTION AMPLIFIER

2.1 Time Base Technical Description

V102B and V106A form a grid triggered Miller circuit, the timing components comprising C277, 276, 278, 279, 280, 281 and R279, 280, 281. The Miller is driven by a bistable circuit V104 via diodes MR105 and V105A. MR106 clamps the starting point of the sweep at approx. 97.5V. A fraction of the sawtooth voltage appearing at the cathode of V106A is used to reset the bistable circuit at the end of the sweep. V105B, R276, 278 and C276, 278, 279, 280, 113 prevent retriggering until the end of the hold-off period.

RV145 is the sweep length preset. The bistable circuit is triggered by a positive pulse from the Schmitt trigger circuit via MR103. Negative pulses are removed by diode MR102. The STABILITY control RV161 controls the potential of the grid of V104A at the end of the hold-off period and is set to a point just above the free-running condition for normal triggered operation.

V104A anode waveform provides the drive for the modulator plate of the C.R.T. This brightens the trace during the time base sweep only.

The timing and hold-off capacitors are switched in 10:1 steps, the intermediate 1, 2 and 5 steps being obtained by switching the timing resistor. RV284 is the VARIABLE control giving a continuous variation of 2.5:1 and the calibration is correct in the fully clockwise position only. C281 is set up on the highest time base speed to give 1 μ s/cm sweep speed. The output is taken from the cathode of V106A to the SWEEP OUTPUT terminal and to the X amplifier.

2.2 X Amplifier Technical Description

The sawtooth from the time base and the X shift voltage from RV159 are mixed in a capacity compensated mixing circuit C116, R155, R156, R158 and applied to the grid of the X amplifier. This is a long-tailed pair consisting of V106B and V107B with a 10:1 X gain control RV168 between the cathodes. The push-pull output from the anodes is directly coupled to the CRT X plates. RV167 is the SET SPEED control and is set up with the X GAIN in the fully anti-clockwise (minimum gain) position.

The EXT X input terminal is connected via a 0.1 μ F capacitor to the input grid of the X amplifier. When using this facility the time base should be switched off by rotating the VARIABLE control fully anticlockwise. This removes the blanking voltage from the modulator plate of the CRT.

V107A is a cathode follower giving a low impedance 100V supply for the time base.

2.3 Facilities

(1) X Amp Input. The X AMP input socket permits an external signal to be applied to the grid of V106A via a 0.1 microfarad capacitor (C119). When using this facility the time base should be switched off, by operating the switch S103, which is ganged to the control marked VARIABLE. This switch stops the bistable V104 operating and also

removes the flyback suppression output at the anode of V106B from the modulator plate of the CRT.

(2) Sweep Output. The sweep voltage is taken from the cathode of V106A to the socket SWEEP OUTPUT, and can be used to drive an external circuit. This is a positive going sawtooth of approximately 50 V peak to peak amplitude.

3. TIME BASE CONTROLS

3.1 The Stepped Sweep Control

Figure 2.3 shows the stepped sweep control, which consists of a three-gang, 18-way rotary switch (TIME/CM) to which are connected the resistor-capacitor networks for obtaining the required time base speeds. These speeds range from 1 microsecond to 500 milliseconds, ascending in 1, 2 and 5 steps.

3.2 Stability Control

This control (RV151) varies the grid potential of the valve (V104A) and hence the switching level of the multivibrator. It is set to the point just below the free-running condition. The control adjusts the sensitivity of the sweep circuit to incoming signals.

3.3 Preset Speed Adjustment

This is formed by the combination of a small variable preset capacitor (C281, Fig. 2.3), which is mounted on the ganged switch assembly, and a preset panel control (RV167) SET SPEED (Fig. 2.2). The latter is used for the initial calibration of the time base speed from a known 20 millisecond pulse. The capacitor is used for the highest speed (1 microsecond) only.

Details of this adjustment are given in the setting-up instructions (Chapter 6). These calibrations are correct when the Red knob marked VARIABLE is set fully clockwise, and when the Black knob X GAIN is set fully anticlockwise (i.e. at minimum 'X' expansion).

3.4 Variable Sweep Control

This control (RV284) is concentric with the TIME/CM switch. It determines the potential to which the charging resistor is returned, and affords a continuously variable control between the fixed sweep speeds, by decreasing the speed from that set on the stepped sweep control to the next lower setting on the scale.

3.5 'X' Expansion and Trace Length

The X GAIN control (RV168) varies the gain of the push-pull valves (V106B and V107B), thereby controlling the length of the trace. The trace may be expanded up to approximately 10 screen diameters. The preset potentiometer (RV145) in the grid circuit of V104B varies the amplitude of sawtooth into the grid so that the trace length may be controlled with the X GAIN at the minimum position.

3.6 X Shift Control

The variable 'X' shift voltage, adjusted by RV159, is applied in series with the sweep voltage from V106A to the grid of V106B. By this means the trace, with or without expansion, may be moved laterally across the screen to any desired position.

THE VERTICAL DEFLECTION CIRCUITS

1. VERTICAL DEFLECTION AMPLIFIER

Each amplifier consists of four identical double triodes. Direct coupling is used throughout to minimise phase shift, and cathode follower output stages provide low impedance outputs to the CRT Y plates and trigger circuit.

A nine position input attenuator switch (VOLTS/CM) provides frequency compensated attenuation to suit a range of input levels.

2. CIRCUIT DESCRIPTION

2.1 The Input Attenuator (VOLTS/CM Switch)

The circuit of the Input Attenuator is shown in Figure 3.1. The input capacitor (C1) is normally in series with the input to the attenuator, but is short-circuited by S1 in DC operation.

The attenuator has four frequency compensated resistance dividers, which are used singly or in series to give nine division ratios. The first section has ratios of 1, 10 and 100; the second has ratios of 1, 2 and 5.

2.2 The Vertical Deflection Amplifier

The vertical deflection amplifier circuit is shown in Fig. 3.2 (Fig. 3.3 for S52).

The input signal is fed from the attenuator network resistor R11 (Fig. 3.1) to the grid of V1. The input stage, V1, consists of a cathode coupled pair. To maintain the input capacity constant with gain and signal variations, neutralising is applied via C21.

The inductors (L21, L22) in the anode circuits are peaked for optimum pulse response. An out of phase signal appears at the anode of V1A and an in phase signal at the anode of V1B, and these anodes are directly coupled to the cathode followers V2.

Shift is applied to V1B grid via RV33 and the attenuator R29, R27. When the gain is increased to 10 mV/cm, the shift voltage is decreased ten times, by adding R30 in series with R29. A d.c. balance control, RV31, is adjusted so that there is no shift of the trace when switching from X1 to X10.

The interstage cathode follower couples the signal to the output stage V3. Transistors TR1 and TR2 are normally shorted out by the X1/X10 switch. When the gain is increased, the transistors are switched into circuit, and the X10 gain is set by RV38, connected between the bases. The large amount of feedback available, via R36, RV38, R41, makes the gain very stable, and unlikely to need adjustment.

The output stage is a standard long tailed pair with inductance compensation (L23, L24) in the anodes.

The Y plate potentials are balanced by RV55, connected between the two amplifier tail resistors. This takes up tolerances in the power supply voltages, anode load resistors and valve currents.

The signal is directly coupled to the output cathode followers V4, and then to the CRT Y plates.

R50, R51 are connected between grid and cathode of V4 to prevent exceeding the grid-cathode voltage during the warm up period.

H.T. supplies are provided for V1 and V2 from a common resistor P54, included in the cathode circuits of V4A and V4B. This is done to reduce the overall current consumption of the amplifier and to provide a measure of stabilisation so that the overall gain of the amplifier is proportional to the power supply voltage.

Balanced sync signals are taken from the collector loads of TR1 and TR2 to the trigger circuit, and are such that the amplitude of sync signals is switched with the gain control.

CHAPTER 4

THE CATHODE RAY TUBE CIRCUIT (D 52)

1. THE CATHODE RAY TUBE

1.1 General

The cathode ray tube used in this instrument is the Type E 13-12. It has a single gun and a splitter plate to split the beam and produce two traces. Each trace then has push pull vertical and horizontal deflector plates.

The CRT is particularly suitable for high speed work having a fine spot and high brightness. The final anode voltage is 3.6kV, and the screen area is 6 x 10 cm.

1.2 Flyback Suppression

An unusual means of flyback suppression is employed by including a "modulator anode" in the CRT. The blanking pulse may be fed at anode potential on to this plate, avoiding direct coupling to the grid of the tube. The advantage of this system is that direct coupling ensures uniform trace brightness at all sweep speeds and complete elimination of the timebase flyback.

2. THE CIRCUIT

2.1 The Cathode Ray Tube circuit is shown in Figure 4.1. The Oscilloscope Power Supplies are shown in Figure 5.1. A separate heater winding on the mains transformer (T401, Fig. 5.1) permits the cathode of the tube to be coupled to the heater, to avoid a large potential difference between the two.

The sawtooth scanning voltages from the timebase (see Fig. 2.2) are applied in antiphase to the two Horizontal Deflection Plates (X plates) of the CRT. (Side-pin connections are used.) The use of pushpull scanning reduces trapezoidal distortion of the trace on the screen.

The voltage under examination is applied to the Vertical Deflection Plates (Y plates), as antiphase outputs from the Vertical Deflection amplifier.

The BRIGHTNESS control (RV310) sets the d.c. level of the grid with respect to the cathode, thus controlling the tube beam current.

The FOCUS control (RV303) sets the potential of the second anode, thus permitting the electron beam to be focussed.

2.2 Z MOD Socket

A socket marked Z MOD, at the rear of the instrument is connected via a blocking capacitor to the grid of the CRT. A positive marker pulse applied at this socket will brighten the trace, permitting the rise time of a squarewave to be measured. The time constant of the Z MOD input circuit is about 10 milliseconds (i.e. $0.01 \mu\text{f} \times 1 \text{ megohm}$).

THE CATHODE RAY TUBE CIRCUIT (S 52)

1. THE CATHODE RAY TUBE

1.1 General

The Cathode Ray Tube used in this instrument is the Type D13-30. It has a 5 inch (13 cm) screen, employs spiral post-deflection acceleration, and electrostatic focusing and deflection. The final anode voltage is 2.4 kV. Screen area is 10 x 10 cm.

1.2 Flyback Suppression

An unusual means of flyback suppression is employed by including a "modulator anode" in the CRT. The blanking pulse may be fed at anode potential on to this plate, avoiding direct coupling to the grid of the tube. The advantage of this system is that direct coupling ensures uniform trace brightness at all sweep speeds and complete elimination of the timebase flyback.

2. THE CIRCUIT

2.1 The Cathode Ray Tube circuit is shown in Figure 4.2. The Oscilloscope Power Supplies are shown in Figure 5.2. A separate heater winding on the mains transformer (T401, Fig. 5.2) permits the cathode of the tube to be coupled to the heater, to avoid a large potential difference between the two.

The sawtooth scanning voltages from the timebase (see Fig. 2.2) are applied in antiphase to the two Horizontal Deflection Plates (X plates) of the CRT. The use of pushpull scanning reduces trapezoidal distortion of the trace on the screen.

The voltage under examination is applied to the Vertical Deflection Plates (Y plates), as antiphase outputs from the Vertical Deflection amplifier.

The BRIGHTNESS control (RV310) sets the d.c. level of the grid with respect to the cathode, thus controlling the tube beam current.

The FOCUS control (RV303) sets the potential of A2, thus permitting the electron beam to be focussed.

2.2 Z MOD Socket

A socket marked Z MOD, at the rear of the instrument, is connected via a blocking capacitor (C301) to the grid of the CRT. A positive marker pulse applied at this socket will brighten the trace, permitting the rise time of a squarewave to be measured. The time constant of the Z MOD input circuit is about 10 milliseconds (i.e. $0.1\mu\text{F} \times 1\text{M}\Omega$).

2.3 X-Y Facility

The signals from the vertical amplifier are permanently connected to the Y plates, while the horizontal output is taken to S301.

This switch connects the X plates to the outputs of either the horizontal amplifier or the sweep amplifier.

When this X-Y facility is used, the time base is automatically switched off by S301, so setting the modulator plate to A1 potential. This then brightens the trace.

POWER SUPPLIES

1. INTRODUCTION

The Power Supply schematic is shown in Figure 5.1. All the rectifiers used are semiconductor diodes, thus ensuring a minimum of delay for the rectified voltages to obtain their maximum value.

2. CIRCUITRY

The mains transformer (T401) provides all the required voltages from its secondaries. The primary may be adjusted, by means of a link input voltage selector panel, for operation on alternating voltages from 100 - 125 V and 200 - 250 V, 50 - 60 Hz.

2.1 HT Supplies

The silicon rectifiers (MR401, MR402), together with C404 and C405, form a voltage doubling circuit. This supplies the various HT voltages via smoothing and decoupling components. The values of the available HT voltages are shown against the appropriate outputs in Figure 5.1. Voltages on valve electrodes, where applicable, are similarly shown in the related schematics.

2.2 E.H.T. Voltages

The E.H.T. voltage for the CRT is derived from the 680 V tapping (780 V tapping for S52) via silicon rectifiers MR403, 404, 405 and capacitors C406, 407, 408.

A 1,070 V transformer tapping supplies the post deflection accelerator voltage: MR408 and MR409 are the rectifiers in a voltage

doubling circuit. (For the S52 MR409 is the rectifier in a half wave rectifier circuit).

2.3 Low Tension

The secondary windings of T401 include a low tension winding, giving 6.3V and 12.6V. This provides heater supplies and pilot light. A separate 6.3V winding is used for the heater of the CRT (see Chapter 4 Section 2.1). This avoids a large potential difference between the heater and cathode.

2.4 Calibrating Voltage

A square wave of 0.5V peak to peak is provided for calibrating purposes as described in Chapter 6. This is obtained by applying the 146V tapping on T401 to a zener diode MR406, via C403 and R401. The voltage across MR406 is then attenuated by R402, R403 and RV404 to provide 0.5V square wave. The temperature coefficient of R402 is selected to match that of the zener diode, so effecting compensation over a wide variation of temperature.

2.5 A negative supply is obtained by rectifying the 12.6V winding via MR407 and reservoir capacitor C410. This voltage is smoothed by R414, C415 and R405, C416 and emitter follower TR401 to provide a -12V supply at low impedance for the vertical amplifier and trigger circuit.

MAINTENANCE, SERVICING AND SETTING-UP PROCEDURE

1. GENERAL

The circuit simplicity of the S52 and D52 Oscilloscopes makes for good reliability, and for the most part, servicing will be limited to the replacement of defective tubes. Replacement of tubes in the vertical amplifier will have very little effect on its performance and no readjustment should be necessary. In the sweep generator and horizontal amplifier the tubes are not particularly critical and you will find that you can replace these without having to alter the internal adjustments. If for any reason the internal preset controls do require adjustments, the following detailed instructions will allow these to be carried out quickly and accurately. For removal of the cover unscrew the carrying handle and the two screws at the bottom corners at the rear.

2. AMPLIFIER TEST PROCEDURE

2.1 Adjust shift and DC bal. controls

Set the GAIN to X1 and centre the trace using the Y SHIFT control. Set the GAIN to X10 and re-centre the trace using the DC BAL control. Repeat the above procedure until there is no shift of the trace when switching from X1 to X10 gain settings.

2.2 Adjusting neutralising capacitor C21

Switch the attenuator to 0.2V range (X1 Gain setting) and connect a 1 kHz (approx.) square wave. Turn the preset SET GAIN control to minimum and adjust the attenuator trimmer capacitor C12 for the square wave to have no overshoot or rounded corners. Turn the SET GAIN to maximum and adjust the neutralising condenser C21

for the waveform to be square. Repeat the above procedure until there is no change of shape as the SET GAIN control is varied from maximum to minimum.

2.3 Gain Setting, RV23, RV38

Switch to X1 and .1 VOLTS/CM and adjust the preset GAIN using the cal. waveform. This gives 5 cm of trace height. Switch to X10 position and 1 VOLTS/CM and adjust the preset control RV38, to provide 5 cm of trace height.

2.4 Attenuator adjustment

In order to carry out this adjustment a square wave generator is required, giving a frequency of approximately 2 kHz; its output must be variable between 0.2V and 100V. The rise time of the square wave need not be particularly fast, but it must have good, flat tops and bottoms. The adjustment procedure is as follows:

Connect the square wave generator to the INPUT socket and adjust its output to approximately 0.2V.

Set the input attenuator to .1 volt/cm. Adjust the sweep controls to display three cycles of the square wave on the screen.

Adjust each capacitor in turn, to give square corners to the waveform. The input attenuator switch should be turned to the appropriate setting as shown in the table below. At the same time, adjust the output of the square wave generator to give a trace of 2 - 3 cm amplitude in each case. The capacitor location is shown in Plate No. 4.

<u>Input Attenuator Setting</u>	<u>Capacitor to be Adjusted</u>
.2 VOLTS/CM	C12
.5 "	C13
1.0 "	C4
2.0 "	C8
5.0 "	C9
10.0 "	C5

When this procedure is correctly carried out, the 20 volts/cm and 50 volts/cm ranges are automatically correct.

2.5 Adjustments for using probe

The capacitors C2 and C3 affect compensation only when the high impedance probe is in use. To adjust them proceed as follows: Remove the square wave generator from the input socket and plug in the high impedance probe. Connect the output of the generator to the probe tip. Set the input attenuator to .1 VOLTS/CM and the square wave generator output to give approximately 2 cm vertical deflection. Adjust the probe trimmer to give a flat top to the square wave. Switch the input attenuator to the 1 VOLTS/CM range. Re-adjust the square wave generator output as before, and adjust C2. Set the input attenuator to the 10 VOLTS/CM range and adjust C3. All other ranges will automatically be correct.

2.6 Set Y plate potential (D 52 only)

Centre each trace and check that both individual pairs of Y plates are at equal d.c. potentials. Then measure the voltage between the two sets of Y plates and adjust RV55 so that there is less than 3V between each pair of plates.

2.7 Set Y plate potential (S 52 only)

Switch to X-Y and connect the CAL waveform to both inputs, one AC and the other DC coupled. This gives a rectangular picture. Adjust RV55 for best focus and astigmatism (See Section 6.2 page 30).

2.8 High frequency compensation (D 52 only)

Use a square wave generator of approx. 200 kHz repetition rate, better than 0.02 μ s rise time and no overshoot. On the .1 VOLTS/CM range and X1 Gain setting, adjust L21, 22, 23, 24 for optimum pulse response. Check bandwidth, this should be 3dB at 6 MHz.

2.9 High frequency compensation (S 52 only)

Switch to X-Y facility. Connect a sine wave generator, at approx. 50 kHz to both vertical and horizontal amplifier inputs. Set the coils in the horizontal amplifier to maximum inductance and adjust the coils in the vertical amplifier so that there is no phase shift as the frequency is increased to 2-3 MHz. Limit the display amplitude to about 4 cm at this frequency.

3. TIME BASE TEST PROCEDURE

3.1 Initial Adjustments

Set RV132 to mid-position.
Set RV124 fully clockwise.
Set SET SPEED (RV172) to mid-position.
Set LEVEL control to mid-position.
Set X GAIN fully anti-clockwise.
Set TIME/CM to 1 mSEC/CM.
Set VARIABLE to Cal.

3.2 Turn STABILITY control fully clockwise and adjust TRACE LENGTH (RV145) to give approximately 50V of sawtooth at the sweep output socket.

3.3 Turn STABILITY control fully anti-clockwise and if time base does not stop, turn TRACE LENGTH (RV145) anti-clockwise until it does.

4. TRIGGER CIRCUIT

4.1 Set TIME/CM to 500 μ SEC/CM and LEVEL control to Auto. Set STABILITY control so that time base triggers at Auto frequency.

4.2 Set VOLTS/CM to 2 and connect CAL 0.5V, PP. to input sockets.

4.3 Adjust RV124 to give maximum trigger sensitivity without multi-triggering on both +ve and -ve.

4.4 Set VOLTS/CM to 0.1 and adjust RV132 so that LEVEL control operates symmetrically about its mid-position on both +ve and -ve.

4.5 Re-check RV124 setting.

5. SWEEP GENERATOR AND X AMPLIFIER

5.1 Set TIME/CM to 1mSEC/CM and display a 1 kHz crystal controlled waveform. Adjust SET SPEED (RV172) to give one cycle per cm. Remove input and turn STABILITY control fully clockwise and adjust TRACE LENGTH (RV145) to give slightly more than 10 cm of trace.

5.2 Remove lead from Mod. Plate (Pin 7) on CRT and set TIME/CM to 10 μ SEC/CM. Increasing C116 will produce a small 'tail' to the left of the spot at the start of the time base. The correct setting of C116 is that at which the 'tail' just disappears into the spot. Turn X GAIN to maximum and adjust neutralising by bending wire connected to anode of V107A until 'tail' just disappears. Check setting of C116 at minimum gain and repeat until rotating the X GAIN from maximum to minimum procedures no 'tail' on the spot in either direction. Reconnect lead to Mod. Plate.

5.3 Set TIME/CM to 1 μ SEC/CM and display a 1 MHz crystal controlled waveform. Adjust C281 to give one cycle per cm.

6. CRT CIRCUIT ADJUSTMENTS

6.1 CRT Cathode Current

The cathode current of the CRT is adjusted by measuring the voltage across R313 with a 20 kilohms/volt meter, or similar instrument, and adjusting RV300, so that the meter reads 0.5 volts. BRIGHTNESS should be at maximum for this adjustment.

6.2 Astigmatism (RV311)

Connect the CAL signal to the input socket and adjust the trace for normal brightness, then focus the trace and adjust RV311 so that both horizontal and vertical edges are in focus.

6.3 Mod. Plate Potential (RV307)

Turn the STABILITY control clockwise so that there is a line displayed, and adjust RV307 for maximum brightness. Then, varying the brightness control should not vary the trace length. If it does, readjust RV307 for maximum brightness consistent with no trace shortening as the brightness control is varied.

6.4 Beam Brightness Equalisation (D 52 only)

The magnet on the back of the CRT base should be rotated to make the two traces have equal brightness.

Set the trace brightness to a low level and adjust the magnet so that the two beams have equal brightness.

7. ADJUSTMENTS IN THE POWER SUPPLY CIRCUIT

7.1 The Calibration Voltage

The preset variable resistor (RV404) in the calibration voltage supply circuit (Power Supply Circuit, Fig. 5.1) is provided so that the output voltage can be set to precisely 0.5 volt peak to peak. This adjustment can only be made by comparing the calibration voltage with a known, accurate 0.5 volt peak to peak signal.

In practice RV404 should not require adjustment. RV404 is located on the large printed board, at the rear of the instrument.

CHAPTER 7

COMPONENTS LIST

Circuit references suffixed with D or S refer to the D52 or S52 respectively.

All resistor and capacitor values are stated in ohms and microfarads respectively unless otherwise shown. Ratings are similarly stated in watts and volts at 70°C.

Carbon resistors are 10% $\frac{1}{4}$ W unless otherwise shown.

Whenever possible exact replacements for components should be used. These may be ordered from the company or its agents stating:-

- | | | | |
|-----|-----------------------------|-----|-----------------------|
| (1) | Instrument type | (4) | Component part number |
| (2) | Instrument serial number | (5) | Component value |
| (3) | Component circuit reference | | |

For standard components, locally available alternatives may be satisfactory.

C	Carbon	P	Paper
CER	Ceramic	PC	Polycarbonate
CP	Carbon preset	PE	Polyester
CT	Ceramic trimmer	PS	Polystyrene
CV	Carbon variable	RE	Reversible electrolytic
E	Electrolytic	Se	Selenium
Ge	Germanium	Si	Silicon
HS	High stability carbon	SM	Silver mica
MF	Metal film	WW	Wire-wound
MO	Metal oxide	WWV	Wire-bound variable

TELEQUIPMENT LIMITED

313 Chase Road,
Southgate,
LONDON, N.14.
ENGLAND.

TELEPHONE: 01-882 1166

CABLES: TELEQUIPT LONDON N 14

D52 Y1 & Y2 AMPLIFIERS
S52 X & Y AMPLIFIERS

Cct. ref.	Part number	Value	Description	Tol. %	Rating
R1	319-0005-01	900k	HS	1	$\frac{1}{4}$
R2	319-0119-00	990k	HS	1	$\frac{1}{4}$
R3	319-0096-00	111k	HS	1	$\frac{1}{4}$
R4	319-0120-00	10. 1k	HS	1	$\frac{1}{4}$
R5	319-0112-00	500k	HS	1	$\frac{1}{4}$
R6	319-0118-00	800k	HS	1	$\frac{1}{4}$
R7	319-0031-01	1M	HS	1	$\frac{1}{4}$
R8	319-0103-00	250k	HS	1	$\frac{1}{4}$
R9	319-0031-01	1M	HS	1	$\frac{1}{4}$
R10	316-0104-01	100k	C		
R11	316-0820-01	82	C		
R12	316-0180-00	18	C		
R21	316-0222-01	2.2k	C		
R22	316-0222-01	2.2k	C		
RV23	311-0723-00	500	CP	20	$\frac{1}{4}$
R24	316-0222-01	2.2k	C		
R25	316-0222-01	2.2k	C		
R26	316-0125-01	1.2M	C		
*R27	316-0223-01	22k	C		
R28	308-0484-00	7.5	WW	5	2
R29	316-0683-01	68k	C		
R30	316-0106-01	10M	C		
RV31	311-0783-00	100k	CP	20	$\frac{1}{4}$
R32D Y1	316-0224-01	220k	C		
Y2	316-0824-01	820k	C		
S Y	316-0274-01	270k	C		
X	316-0105-01	1M	C		
RV33	311-1002-00	100k	CV	20	$\frac{1}{4}$
R34	307-0159-00	6.8k	MO	5	2
R35D	303-0822-01	8.2k	C	5	1
S	303-0153-01	15k	C	5	1
R36D	316-0562-01	5.6k	C		
S	316-0153-01	15k	C		

* One component per instrument, common to both amplifiers

Carbon resistors are 10% $\frac{1}{4}$ W unless otherwise shown

D52 Y1 & Y2 AMPLIFIERS
S52 X & Y AMPLIFIERS contd.

Cct. ref.	Part number	Value	Description	Tol. %	Rating
R37D	316-0154-01	150k	C		
S	316-0394-01	390k	C		
RV38	311-0734-00	5k	CP	30	0.1
R39D	316-0154-01	150k	C		
S	316-0394-01	390k	C		
R40	316-0331-01	330	C		
R41D	316-0562-01	5.6k	C		
S	316-0153-01	15k	C		
R42D	303-0822-01	8.2k	C	5	1
S	303-0153-01	15k	C	5	1
R43	316-0180-01	18	C		
R44	316-0180-01	18	C		
R45D	307-0158-00	3.3k	MO	5	2
S	307-0166-00	4.7k	MO	5	$3\frac{1}{4}$
R46D	307-0166-00	4.7k	MO	5	$3\frac{1}{4}$
S	308-0474-00	12k	WW	5	$3\frac{1}{2}$
R47D	307-0166-00	4.7k	MO	5	$3\frac{1}{4}$
S	308-0474-00	12k	WW	5	$3\frac{1}{2}$
R48	316-0101-01	100	C		
R49	316-0101-01	100	C		
R50	316-0153-01	15k	C		
R51	316-0153-01	15k	C		
R52D	307-0183-00	2.7k	MO	5	$3\frac{1}{4}$
S	305-0562-01	5.6k	C	5	2
R53D	307-0183-00	2.7k	MO	5	$\frac{1}{4}$
S	305-0562-01	5.6k	C	5	2
R54S	316-0683-01	68k	C		
*RV55	311-0787-00	1.5k	WWP	10	$\frac{1}{4}$
R56	316-0153-01	15k	C		
R57	316-0153-01	15k	C		
R58	316-0106-01	10M	C		
R59	316-0106-01	10M	C		
*R60	316-0223-01	22k	C		
R61	316-0101-01	100	C		
R62	316-0101-01	100	C		

* One component per instrument, common to both amplifiers

D52 Y1 & Y2 AMPLIFIERS
S52 X & Y AMPLIFIERS contd.

<u>Cct. ref.</u>	<u>Part number</u>	<u>Value</u>	<u>Description</u>	<u>Tol. %</u>	<u>Rating</u>
C1	285-0772-00	0.1	PE	20	400
C2	281-0137-00	6-30p	CT		350
C3	281-0137-00	6-30p	CT		350
C4	281-0137-00	6-30p	CT		350
C5	281-0137-00	6-30p	CT		350
C6	285-0854-00	100p	PS	2p	350
C7	285-0850-00	1,000p	PS	5	125
C8	281-0137-00	6-30p	CT		350
C9	281-0137-00	6-30p	CT		350
C10	285-0842-00	15p	PS	1p	500
C11	285-0867-00	20p	PS	1p	500
C12	281-0137-00	6-30p	CT		350
C13	281-0137-00	6-30p	CT		350
C14	285-0843-00	30p	PS	2p	500
C15	283-0662-00	7.5p	SM	$\frac{1}{2}$ p	350
C16	285-0769-00	0.01	PE	20	400
C21	281-0128-00	0.7-3p	CT		500
C22	285-0845-00	68p	PS	2p	500
C23	285-0791-00	0.47	PE	10	125
C24	290-0379-00	32	E		275
C25	290-0113-01	8	E		150
C26	285-0796-00	0.1	PE	20	250
C27	285-0796-00	0.1	PE	20	250
C28D	281-0676-00	2.2p	CER	0.1p	500
S	281-0711-00	3.9p	CER	$\frac{1}{4}$ p	750
C29D	281-0676-00	2.2p	CER	0.1p	500
S	281-0711-00	3.9p	CER	$\frac{1}{4}$ p	750
L21D	114-0256-00	15-33 μ H	Variable, 50 turns		
S	114-0260-00	22-51 μ H	Variable, 70 turns		
L22	114-0260-00	22-51 μ H	Variable, 70 turns		
L23D	114-0261-00	39-120 μ H	Variable, 100 turns		
S	114-0261-00	39 μ H	Fixed, 100 turns		
L24D	114-0261-00	39-120 μ H	Variable, 100 turns		
S	114-0261-00	39 μ H	Fixed, 100 turns		

D52 Y1 & Y2 AMPLIFIERS
S52 X & Y AMPLIFIERS contd.

<u>Cct. ref.</u>	<u>Part number</u>	<u>Value</u>	<u>Description</u>	<u>Tol. %</u>	<u>Rating</u>
* MR21	152-0062-01		1N914 Si		
* MR22	152-0062-01		1N914 Si		
S1	260-0926-00		Slide		
S2	260-0953-00		Rotary		
S21	260-0972-00		Push		
FR1	151-0244-00		2N3702 Texas Si		
TR2	151-0244-00		2N3702 Texas Si		
V1	154-0187-01		ECC88/6DJ8		
V2	154-0187-01		ECC88/6DJ8		
V3	154-0187-01		ECC88/6DJ8		
V4	154-0187-01		ECC88/6DJ8		

* One component per instrument, common to both amplifiers

D52 & S52 TIMEBASE

Cct. ref.	Part number	Value	Description	Tol. %	Rating
R100	316-0106-01	10M	C		
R101	316-0105-01	1M	C		
R102	316-0101-01	100	C		
R103	316-0682-01	6.8k	C		
R104	316-0332-01	3.3k	C		
R105	316-0222-01	2.2k	C		
R106	316-0101-01	100	C		
R107	316-0105-01	1M	C		
RV108	311-0740-00	100k	CV (with RV161 & S104)	20	2
R109	316-0275-01	2.7M	C		
R110	316-0823-01	82k	C		
R111	316-0275-01	2.7M	C		
R112	316-0101-01	100	C		
R113	316-0180-01	18	C		
R114	303-0183-01	18k	C	5	1
R115	316-0103-01	10k	C		
R116	316-0334-01	330k	C		
R117	316-0684-01	680k	C		
R118	316-0104-01	100k	C		
R119	316-0101-01	100	C		
R120	316-0273-01	27k	C		
R121	316-0563-01	56k	C		
R122	316-0474-01	470k	C		
R123	316-0222-01	2.2k	C		
RV124	311-0725-00	500	CP	30	0.1
R125	316-0102-01	1k	C		
R126	303-0183-01	18k	C	5	1
R127	316-0104-01	100k	C		
R128	316-0101-01	100	C		
R129	316-0103-01	10k	C		
R130	316-0180-01	18	C		
R131	316-0563-01	56k	C		
RV132	311-0760-00	50k	CP	30	0.1

Carbon resistors are 10% $\frac{1}{4}$ W unless otherwise shown

D52 & S52 TIMEBASE contd.

Cct. ref.	Part number	Value	Description	Tol. %	Rating
R133	316-0105-01	1M	C		
R134	316-0101-01	100	C		
R135	302-0683-01	68k	C	10	$\frac{1}{2}$
R136	316-0473-01	47k	C		
R137	316-0332-01	3.3k	C		
R138	316-0153-01	15k	C		
R139	316-0101-01	100	C		
R141	316-0184-01	180k	C		
R143	316-0154-01	150k	C		
R144	316-0683-01	68k	C		
RV145	311-0770-00	100k	CP	30	0.1
R146	316-0563-01	56k	C		
R147	316-0101-01	100	C		
R148	316-0334-01	330k	C		
R149	316-0101-01	100	C		
R151	316-0105-01	1M	C		
R152	316-0180-01	18	C		
R153	303-0103-01	10k	C	5	1
R154	303-0562-01	5.6k	C	5	1
R155	315-0334-01	330k	C	5	$\frac{1}{4}$
R156	315-0684-01	680k	C	5	$\frac{1}{4}$
R157	316-0273-01	27k	C		
R158	315-0514-01	510k	C	5	$\frac{1}{4}$
RV159	311-0741-00	50k	CV (with RV168)	20	2
RV161	311-0740-00	10k	CV (with RV108 & S104)	20	2
R162	316-0153-01	15k	C		
R163	316-0101-01	100	C		
R164	307-0162-00	15k	MO	5	$3\frac{1}{4}$
R165	316-0101-01	100	C		
R166	304-0103-01	10k	C	10	1
RV167	311-0747-00	25k	CP	20	$\frac{1}{4}$
RV168	311-0741-00	10k	CV (with RV159)	20	2
R169	316-0101-01	100	C		
R171	316-0101-01	100	C		
R172	304-0103-01	10k	C	10	1

D52 & S52 TIMEBASE contd.

<u>Cct. ref.</u>	<u>Part number</u>	<u>Value</u>	<u>Description</u>	<u>Tol. %</u>	<u>Rating</u>
R173	316-0334-01	330k	C		
R174	315-0134-01	130k	C	5	$\frac{1}{4}$
R175	316-0180-01	18	C		
R176	307-0162-00	15k	MO	5	$3\frac{1}{4}$
R177	319-0002-01	150k	HS	1	$\frac{1}{4}$
R178	319-0082-00	91k	HS	1	$\frac{1}{4}$
R179	316-0101-01	100	C		
R276	316-0475-01	4.7M	C		
R277	316-0334-01	330k	C		
R278	316-0474-01	470k	C		
R279	319-0031-01	1M	HS	1	$\frac{1}{4}$
R280	319-0031-01	1M	HS	1	$\frac{1}{4}$
R281	319-0054-01	3M	HS	1	$\frac{1}{4}$
R282	316-0225-01	2.2M	C		
R283	316-0125-01	1.2M	C		
RV284	311-0817-00	1M	CV (with S103)	20	$\frac{1}{4}$
R285	316-0105-01	1M	C		
C100	285-0772-01	0.1	PE	10	400
C101	285-0769-00	0.01	PE	10	400
C102	285-0769-00	0.01	PE	10	400
C103	285-0796-00	0.1	PE	20	250
C104	285-0796-00	0.1	PE	20	250
C105	285-0796-00	0.1	PE	20	250
C106	285-0796-00	0.1	PE	20	250
C108	285-0874-00	470p	PS	5	125
C109	285-0842-00	15p	PS	1p	350
C111	285-0854-00	100p	PS	2p	350
C112	285-0773-00	0.1	PE	20	400
C113	285-0842-00	15p	PS	1p	350
C114	285-0866-00	10p	PS	1p	350
C115	285-0843-00	30p	PS	2p	350
C116	281-0132-00	10-40p	CT		250
C117	285-0773-00	0.1	PE	20	400
C118	285-0790-00	0.01	PE	20	125

D52 & S52 TIMEBASE contd.

<u>Cct. ref.</u>	<u>Part number</u>	<u>Value</u>	<u>Description</u>	<u>Tol. %</u>	<u>Rating</u>
C119	285-0773-00	0.1	PE	20	400
C121	290-0374-00	50	E		150
C122	285-0799-00	0.033	PE	20	250
C123	285-0796-00	0.1	PE	20	250
C276	285-0839-00	0.2	PE	2	160
C277	285-0802-00	2	PE	2	160
C278	285-0778-00	0.02	PE	1	350
C279	285-0860-00	2,000p	PS	2	350
C280	285-0872-00	180p	PS	2	350
C281	281-0137-00	6-30p	CT		350
MR101	152-0062-01		1N914 Si		
MR102	152-0062-01		1N914 Si		
MR103	152-0062-01		1N914 Si		
MR104	152-0062-01		1N914 Si		
MR105	152-0062-01		1N914 Si		
MR106	152-0062-01		1N914 Si		
MR107	152-0062-01		1N914 Si		
MR108	152-0062-01		1N914 Si		
S101	260-0966-00		Push (3- button)		
S102	260-0967-00		Push (3- button)		
S103	311-0817-00		Rotary (with RV284)		
S104	311-0740-00		Rotary (with RV108 & 161)		
S276	260-0950-00		Rotary (18-position)		
V101	154-0278-01		ECF80/6BL8		
V102	154-0278-01		ECF80/6BL8		
V103	154-0187-01		ECC88/6DJ8		
V104	154-0187-01		ECC88/6DJ8		
V105	154-0534-00		EB91/6AL5		
V106	154-0278-01		ECF80/6BL8		
V107	154-0278-01		ECF80/6BL8		

D52 & S52 CRT CIRCUIT

Cct. ref.	Part number	Value	Description	Tol. %	Rating
RV300	311-0752-00	1M	CP	30	0.1
RV301)	311-0824-00	(1M	CV (with S401)	20	$\frac{1}{4}$
RV303)		(1M	CV	20	$\frac{1}{4}$
R302D	316-0274-01	270k	C (for E13-12 CRT)		
	316-0105-01	1M	C (for 55451 CRT)		
S	316-0274-01	270k	C		
R304	316-0155-01	1.5M	C		
R305	316-0105-01	1M	C		
R306	316-0104-01	100k	C		
RV307	311-0760-00	50k	CP	30	0.1
R308	316-0473-01	47k	C		
RV309	311-0799-00	250k	CP	30	0.1
R310	316-0334-01	330k	C		
RV311	311-0799-00	250k	CP	30	0.1
R312	316-0124-01	120k	C		
R313D	316-0102-01	1k	C		
S	316-0272-01	2.7k	C		
R314	316-0106-01	10M	C		
C301	281-0677-00	0.01	CER		1.5k
C302	285-0773-00	0.1	PE	20	400
C303	285-0796-00	0.1	PE	20	250
N301	150-0069-00	60V	Neon 3L		
N302	150-0069-00	60V	Neon 3L		
S301S	260-0955-00		Slide (2-position)		
CRTD	154-0532-00	P31	E13-12GH (12 pin)		
	154-0554-00	P31	55451GH (14 pin)		
	154-0553-00	P7	E13-12GM (12 pin)		
	154-0558-00	P7	55451GM (14 pin)		
	154-0556-00	P11	E13-12BE (12 pin)		
S	154-0522-00	P31	D13-30GH		
	154-0552-00	P7	D13-30GM		
	154-0557-00	P11	D13-30BE		

D52 & S52 POWER SUPPLY

Cct. ref.	Part number	Value	Description	Tol. %	Rating
R401	316-0224-01	220k	C		
R402	322-0670-00	100k	MF	5	$\frac{1}{4}$
R403	319-0105-00	3.6k	HS	1	$\frac{1}{4}$
RV404	311-0763-00	2.5k	CP	30	0.1
R405	316-0181-01	180	C		
R406D	308-0482-00	620	WW	5	2
S	302-0101-01	100	C	10	$\frac{1}{2}$
R407D	308-0482-00	620	WW	5	2
S	302-0101-01	100	C	10	$\frac{1}{2}$
R408D	308-0479-00	1.8k	WW	5	2
S	308-0487-00	820	WW	5	2
R409D	308-0479-00	1.8k	WW	5	2
S	308-0487-00	820	WW	5	2
R411	316-0102-01	1k	C		
R412	308-0487-00	820	WW	5	2
R413	308-0487-00	820	WW	5	2
R414	316-0221-01	220	C		
R415	316-0182-01	1.8k	C		
C401	285-0773-00	0.1	PE	20	400
C402D	285-0766-00	0.05	P	10	2k
C403	285-0773-00	0.1	PE	20	400
C404	290-0351-00	120	E		200
C405	290-0351-00	120	E		200
C406	290-0365-00	16	E		450
C407	290-0365-00	16	E		450
C408	290-0365-00	16	E		450
C409D	285-0765-00	0.05	P	10	3.5k
S	285-0763-00	0.05	P	10	2.5k
C410	290-0385-00	2,000	E (1,000 + 1,000)		18
C411	285-0792-00	4,700p	PE	20	125
C412a)		(32)			
b)	290-0446-00	(32)	E		450
c)		(32)			

Carbon resistors are 10% $\frac{1}{4}$ W unless otherwise shown

D52 & S52 POWER SUPPLY contd.

<u>Cct. ref.</u>	<u>Part number</u>	<u>Value</u>	<u>Description</u>	<u>Tol. %</u>	<u>Rating</u>
C413a)	290-0373-00	(40)	E		350
b)		(40)			
C414a)	290-0373-00	(40)	E		350
b)		(40)			
C415	290-0386-00	250	E		18
C416	290-0386-00	250	E		18
F401	159-0073-00	1A	Fuse $1\frac{1}{4}$ in 200-250V		
	159-0069-00	2A	Fuse $1\frac{1}{4}$ in 100-125V		
LP401	150-0074-00	6.5V	Lamp L.E.S.		0.15A
MR401	152-0341-00	450V	Si rectifier		0.5A
MR402	152-0341-00	450V	Si rectifier		0.5A
MR403	152-0352-00	800V	Si rectifier		0.2A
MR404	152-0352-00	800V	Si rectifier		0.2A
MR405	152-0352-00	800V	Si rectifier		0.2A
MR406	152-0346-00	11V	Si zener		0.33W
MR407	152-0339-00	50V	Si rectifier		0.5A
MR408D	152-0351-00	3.4kV	Se rectifier		5mA
MR409	152-0351-00	3.4kV	Se rectifier		5mA
S401	311-0824-00		Rotary (with RV301 & 303)		
T401	120-0542-00		Power transformer		
TR401	151-0243-00		ACY22 Mullard Ge		

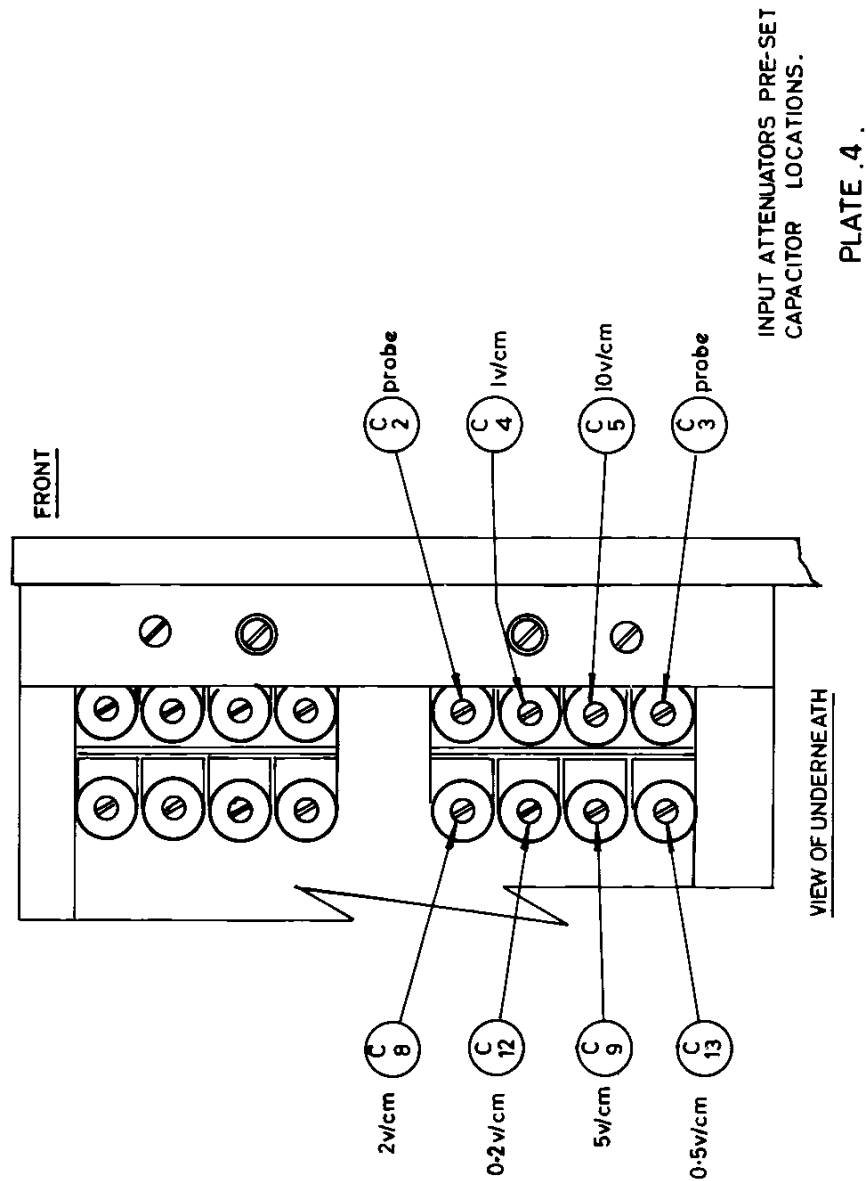

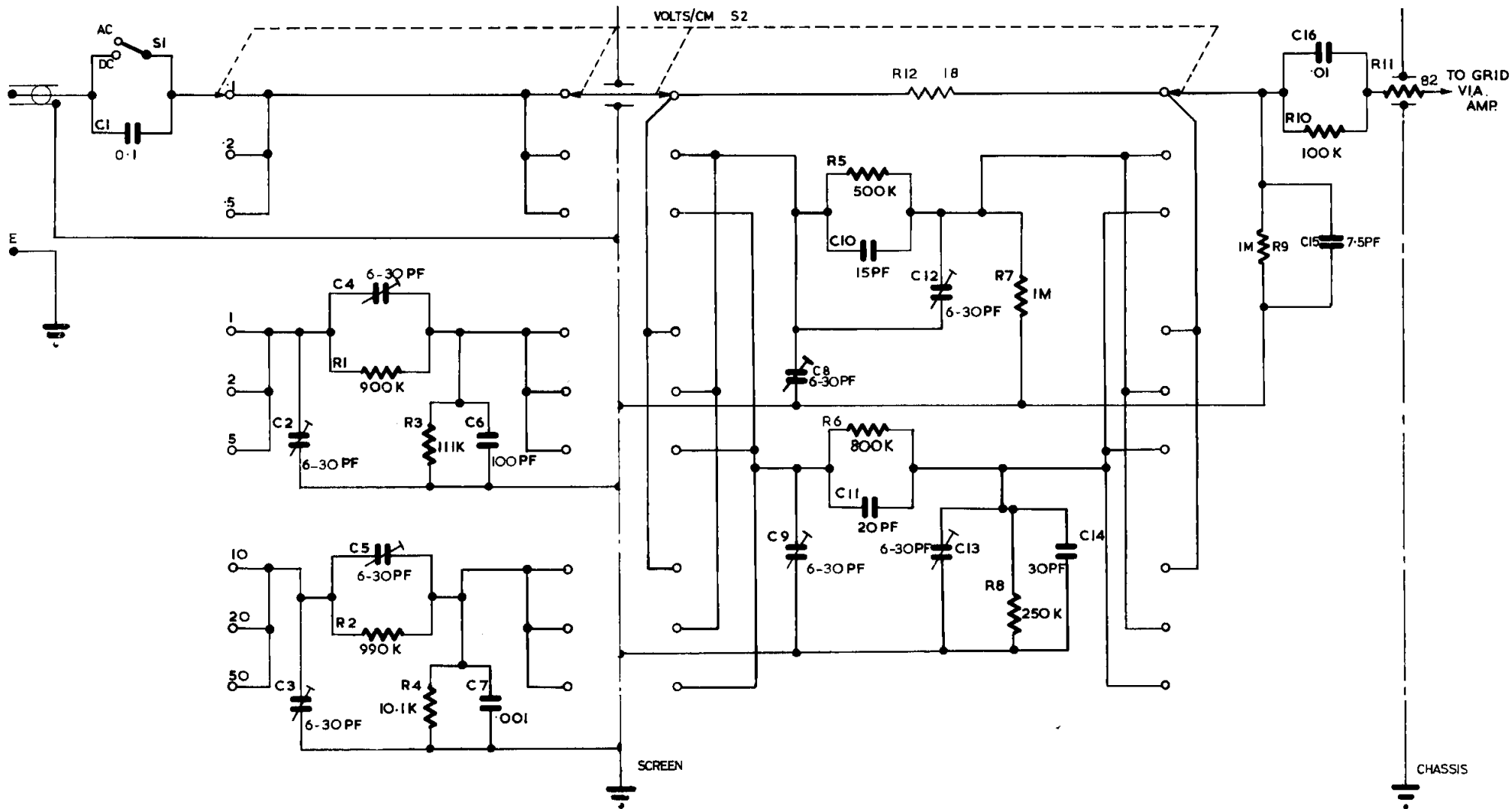

INPUT ATTENUATOR

S52 & D52 FIG 3.1

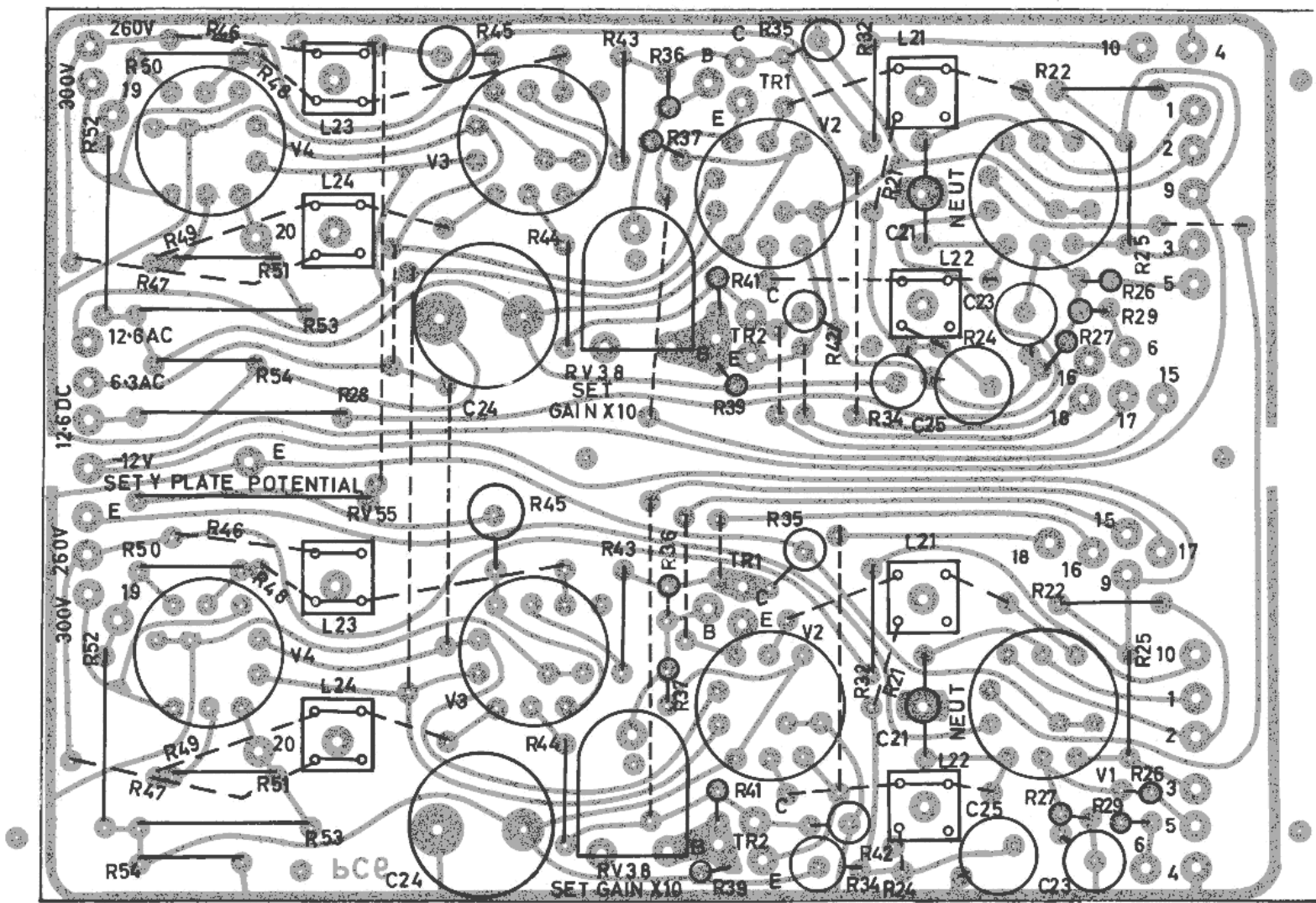
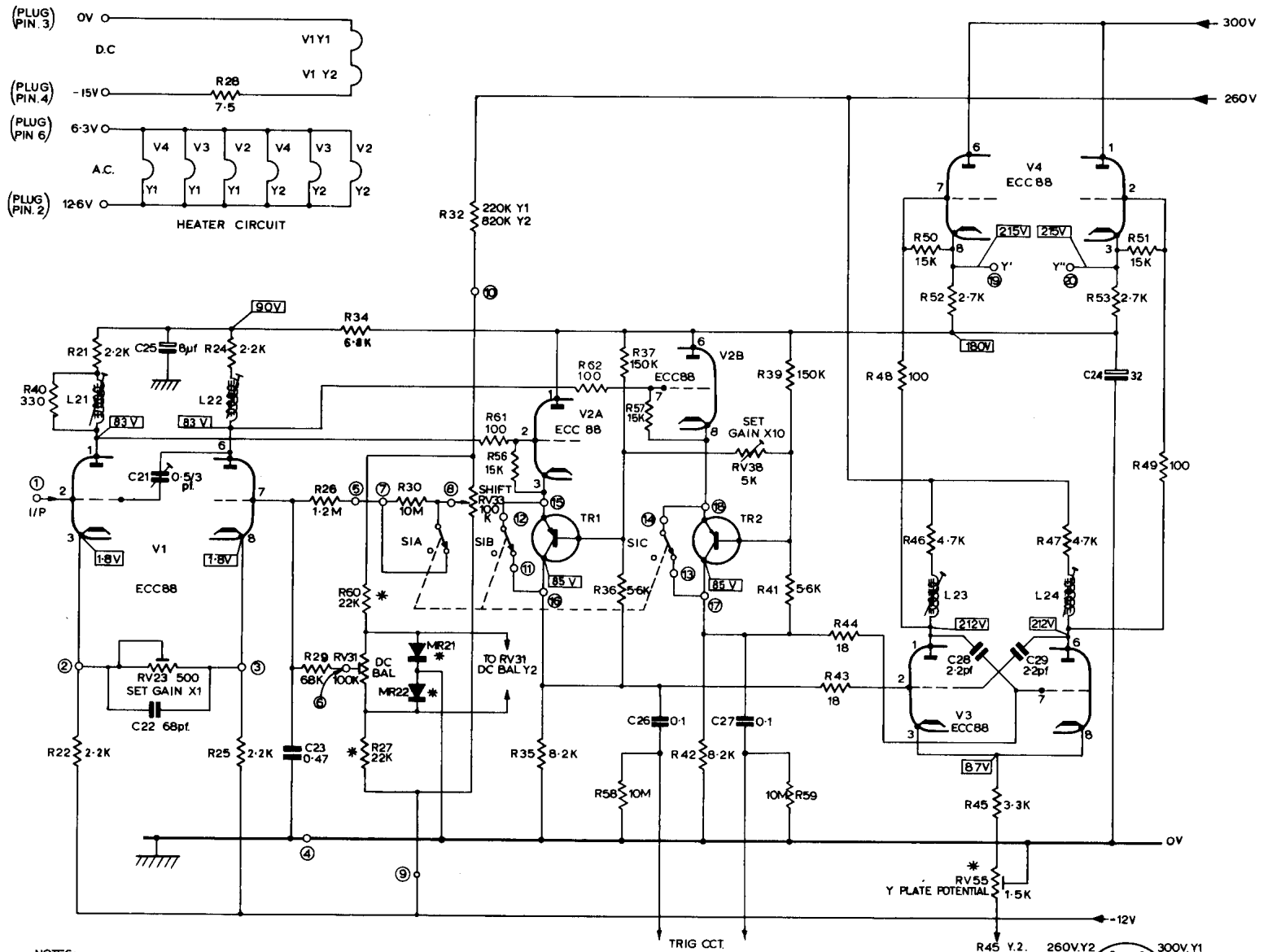

PLATE 2. Y AMPLIFIER PRINTED CIRCUIT BOARD.



NOTES:-

1. (N) DENOTES TAGS ON AMPLIFIER & SWITCH PC BOARD NOS. 7,8,11,12,13,14 ON PC18A.REMAINING NOS. ON PC.6
2. CIRCUIT SHOWN IN X1 POSITION
3. * DENOTES COMPONENTS COMMON TO BOTH Y1 & Y2 AMPLIFIERS

VERTICAL AMPLIFIER D52 FIG 3.2
(Y1 UPPER Y2 LOWER)

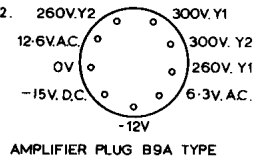

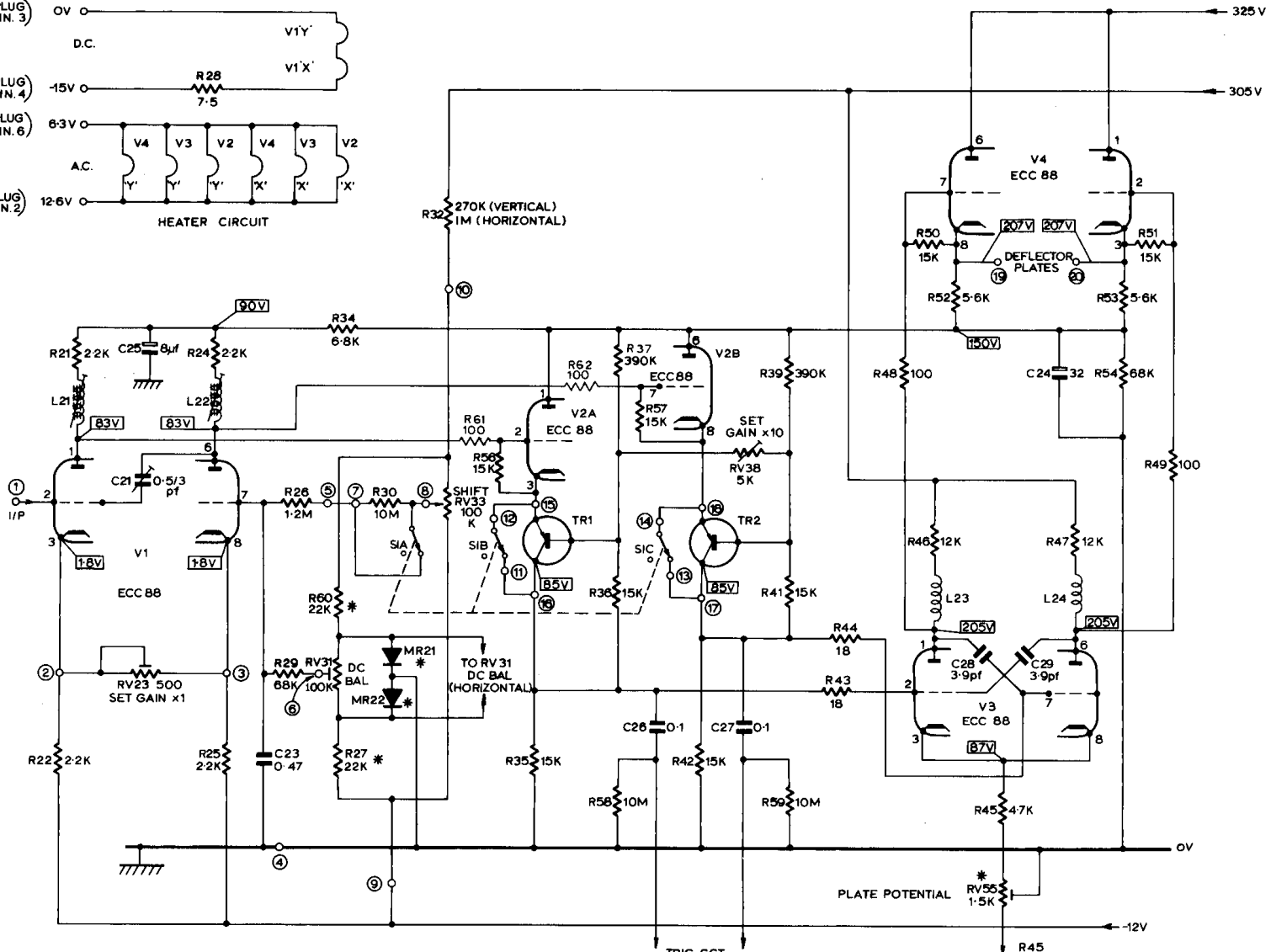
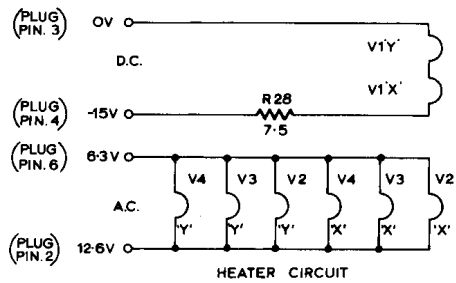

NOTES.

- ① DENOTES TAGS ON AMPLIFIER & SWITCH PC BOARD NOS. 7,8,11,12,13,14 ON PC-18A REMAINING NOS. ON PC. 6.
- CIRCUIT SHOWN IN X1 POSITION.
- * DENOTES COMPONENTS COMMON TO BOTH VERTICAL & HORIZONTAL AMPLIFIERS.

VERTICAL & HORIZONTAL AMPLIFIERS S52 FIG.3-3

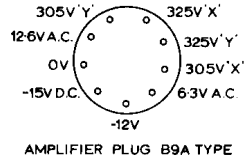

CONNECTIONS FOR S52

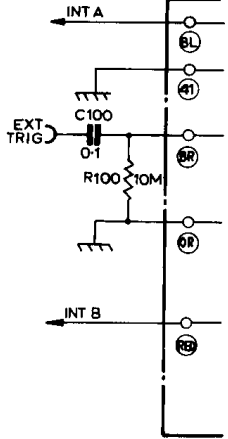

CONNECTIONS FOR D52

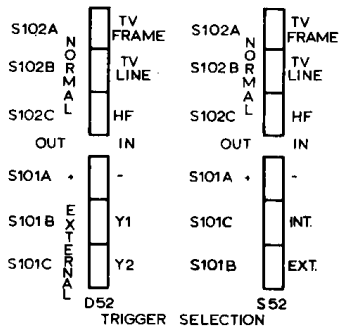
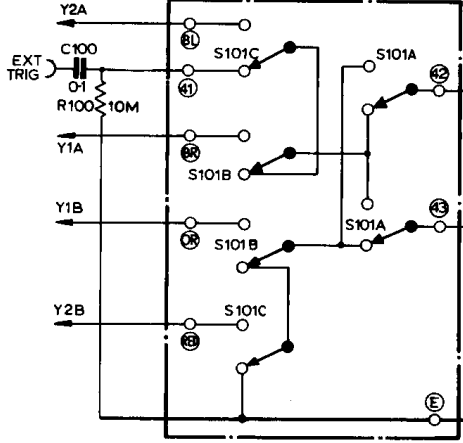

(SWITCHES SHOWN IN OUT POSITION)

- NOTES :-
- Ⓝ DENOTES TAGS ON PC.5 & PC.14
 - * COMPONENTS NOT ON PC. BOARDS

1/2 ECF80

250V

100V

-12V.

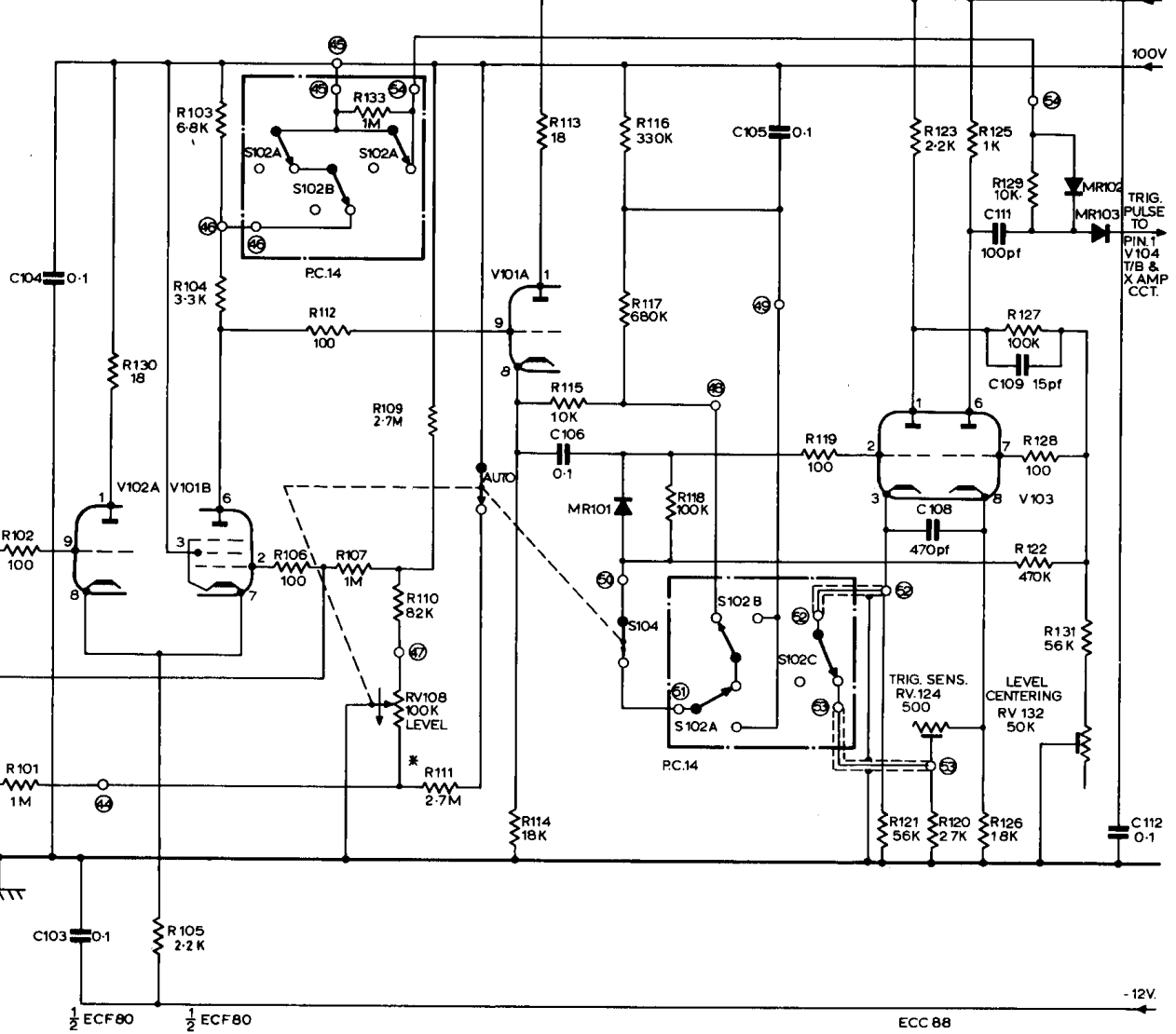

TRIGGER CIRCUIT D52 & S52 FIG 2.1

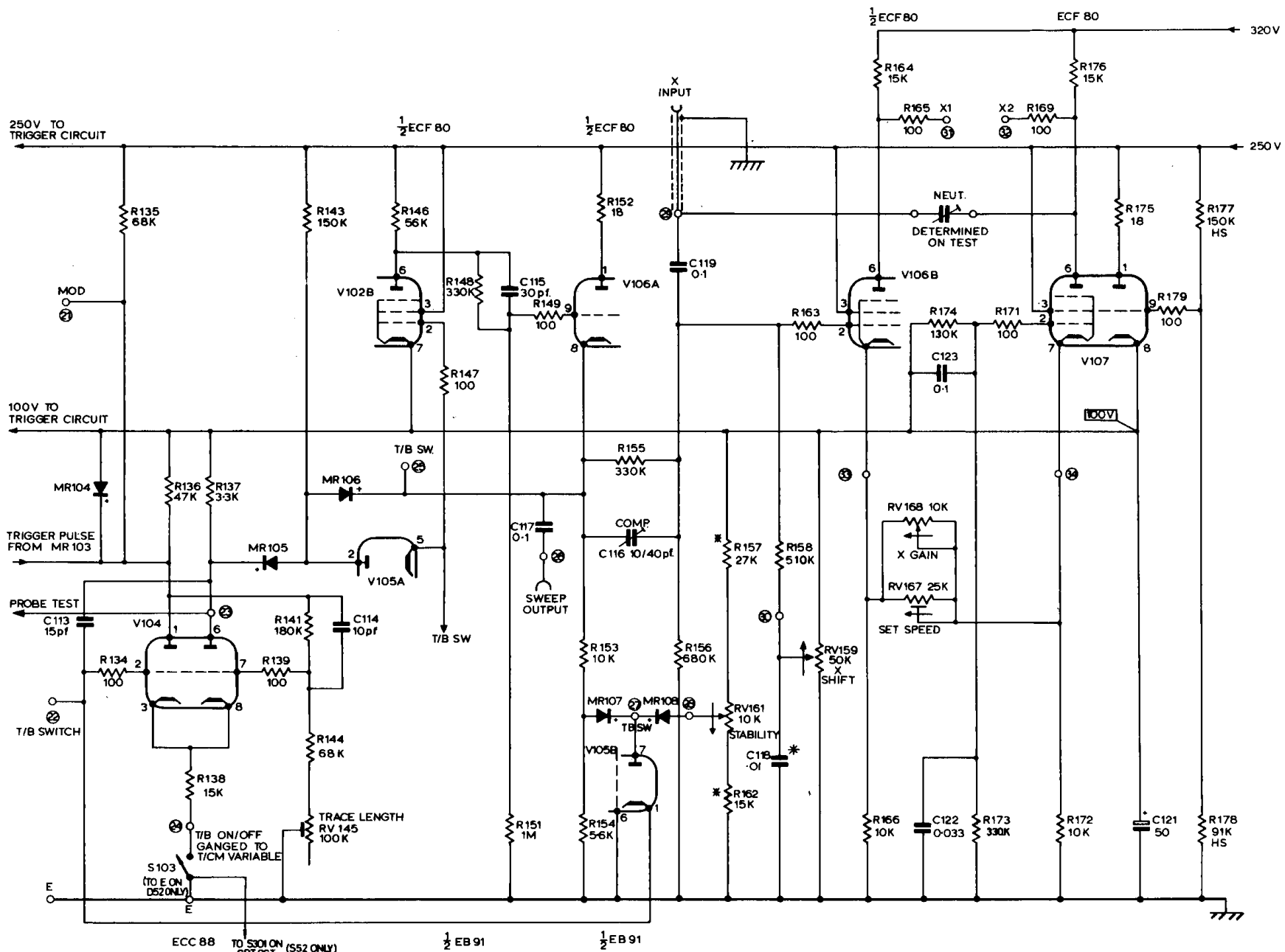

NOTES :-
 1. N. DENOTES TAGS ON PC. 5
 2. * DENOTES COMPONENTS NOT ON PC. 5

TIME BASE & HORIZONTAL AMPLIFIER D52 & S52 FIG 2-2

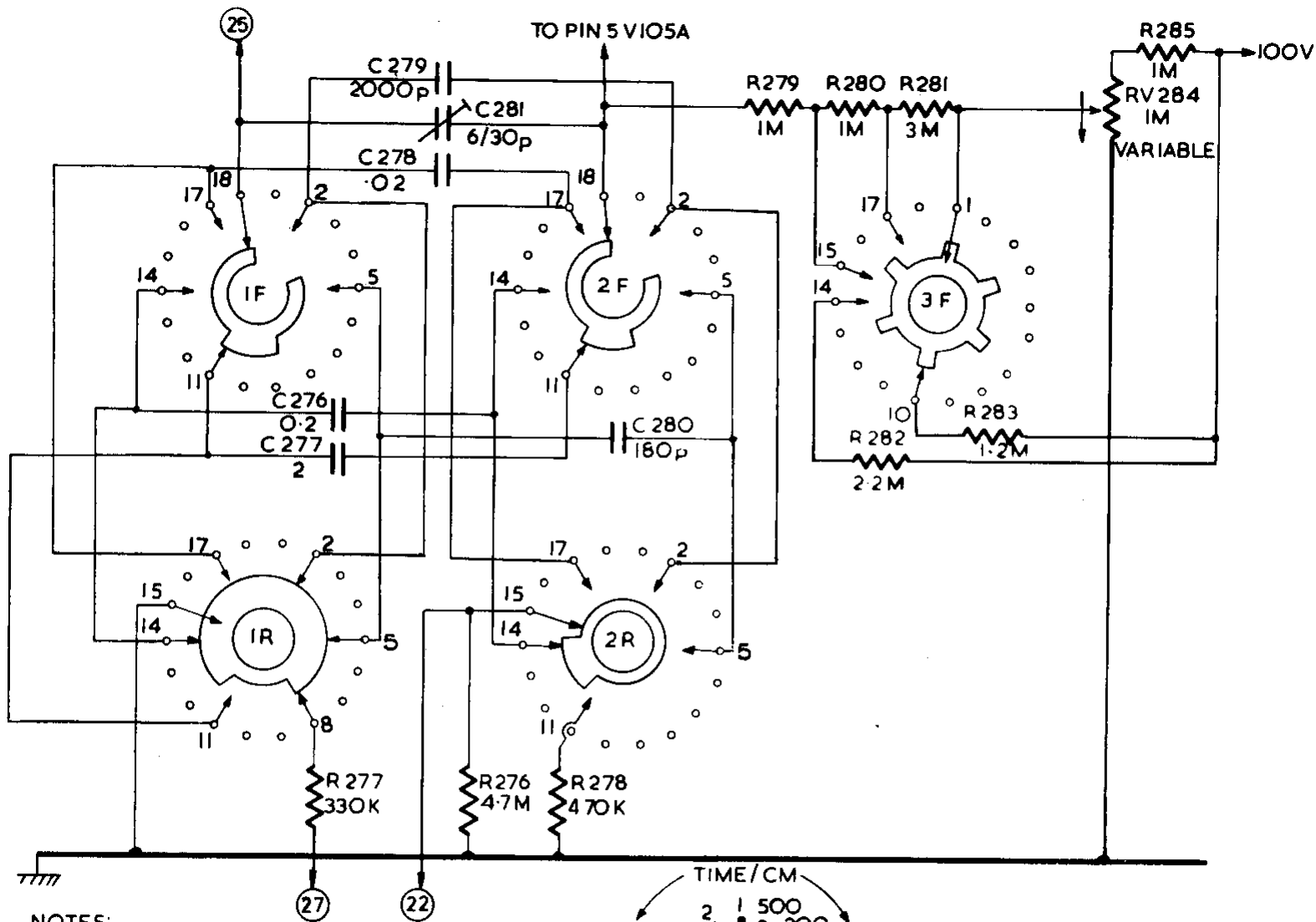

NOTES:-
 I. (No) DENOTES PRINTED CCT.
 TERMINAL NUMBERS.
 (SEE TIMEBASE & HORIZ. AMP CCT)

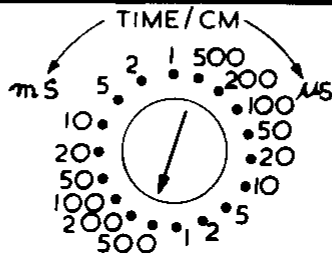

TIME/CM SWITCH
 FIG. 2·3

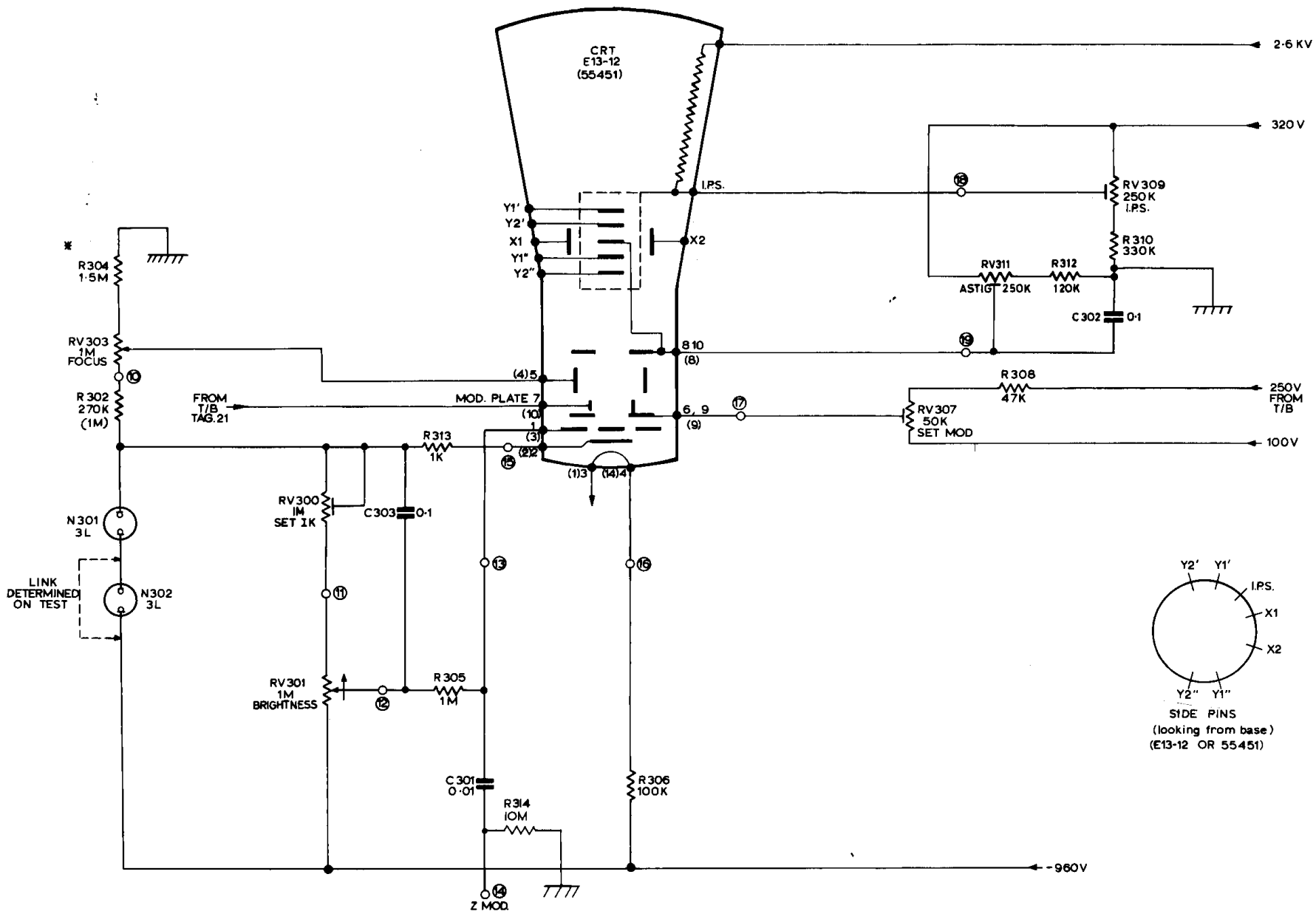

- NOTES:-
1. (N) DENOTES TAGS ON PC.5
 2. * DENOTES COMPONENTS NOT ON PC BOARD
 3. (No) NUMBER DENOTES 14 PIN BASE C.R.T.

C.R.T.CIRCUIT D52 FIG 4.1

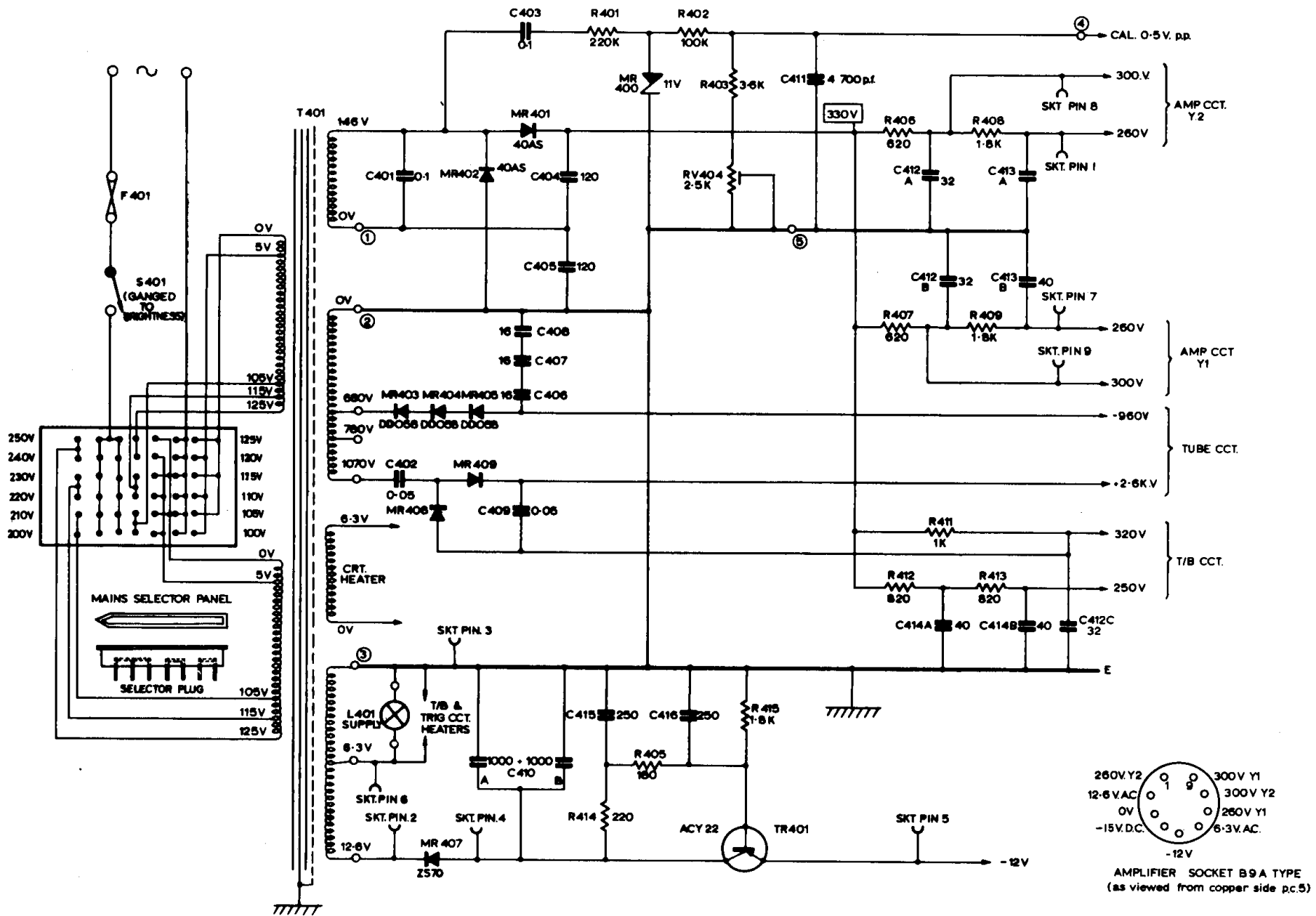

NOTES:
 1. Ⓞ DENOTES TERMINALS ON PC.5
 2. ALL COMPONENTS EXCEPT T401 & MAINS SELECTOR PANEL ON PC.5

POWER SUPPLY CIRCUIT D52 FIG 5-I

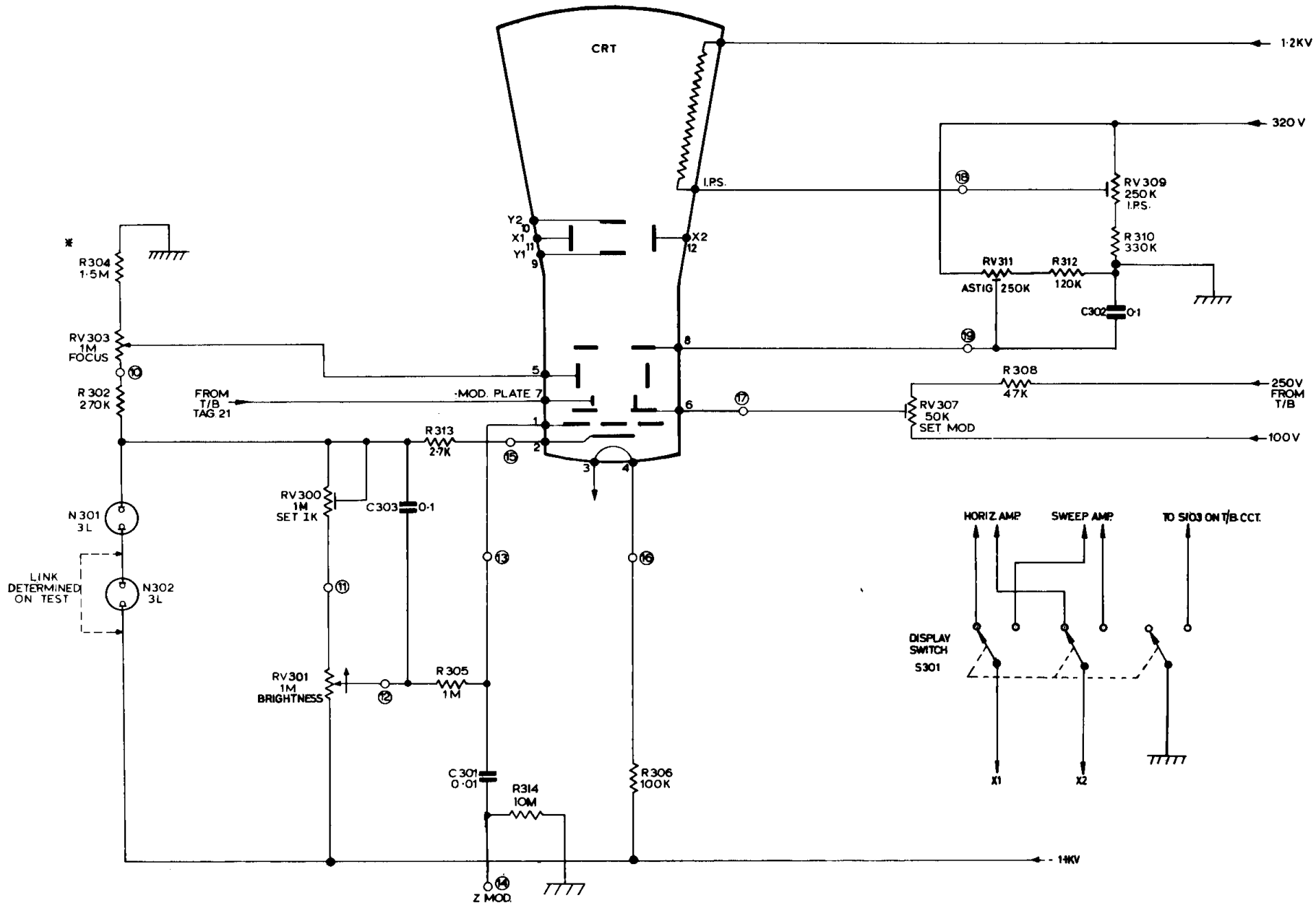

NOTES:-

1. (1) DENOTES TAGS ON PC.5
2. * DENOTES COMPONENTS NOT ON PC BOARD
3. DISPLAY SWITCH IN X-Y POSITION

C.R.T.CIRCUIT S52 FIG 4

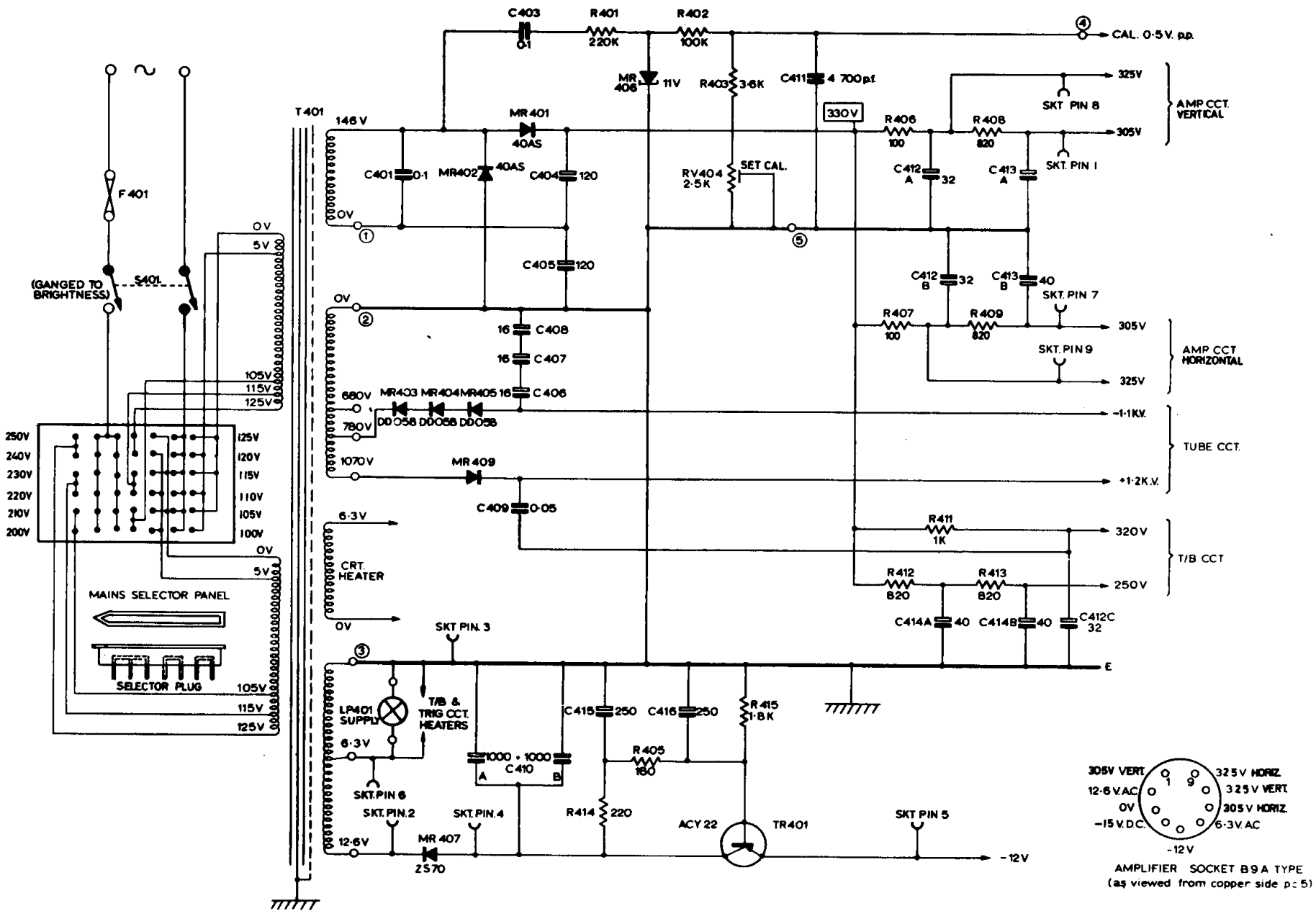

NOTES:
 1. (N) DENOTES TERMINALS ON PC.5
 2. ALL COMPONENTS EXCEPT T401 & MAINS SELECTOR PANEL ON PC.5

POWER SUPPLY CIRCUIT S52 FIG 5.2

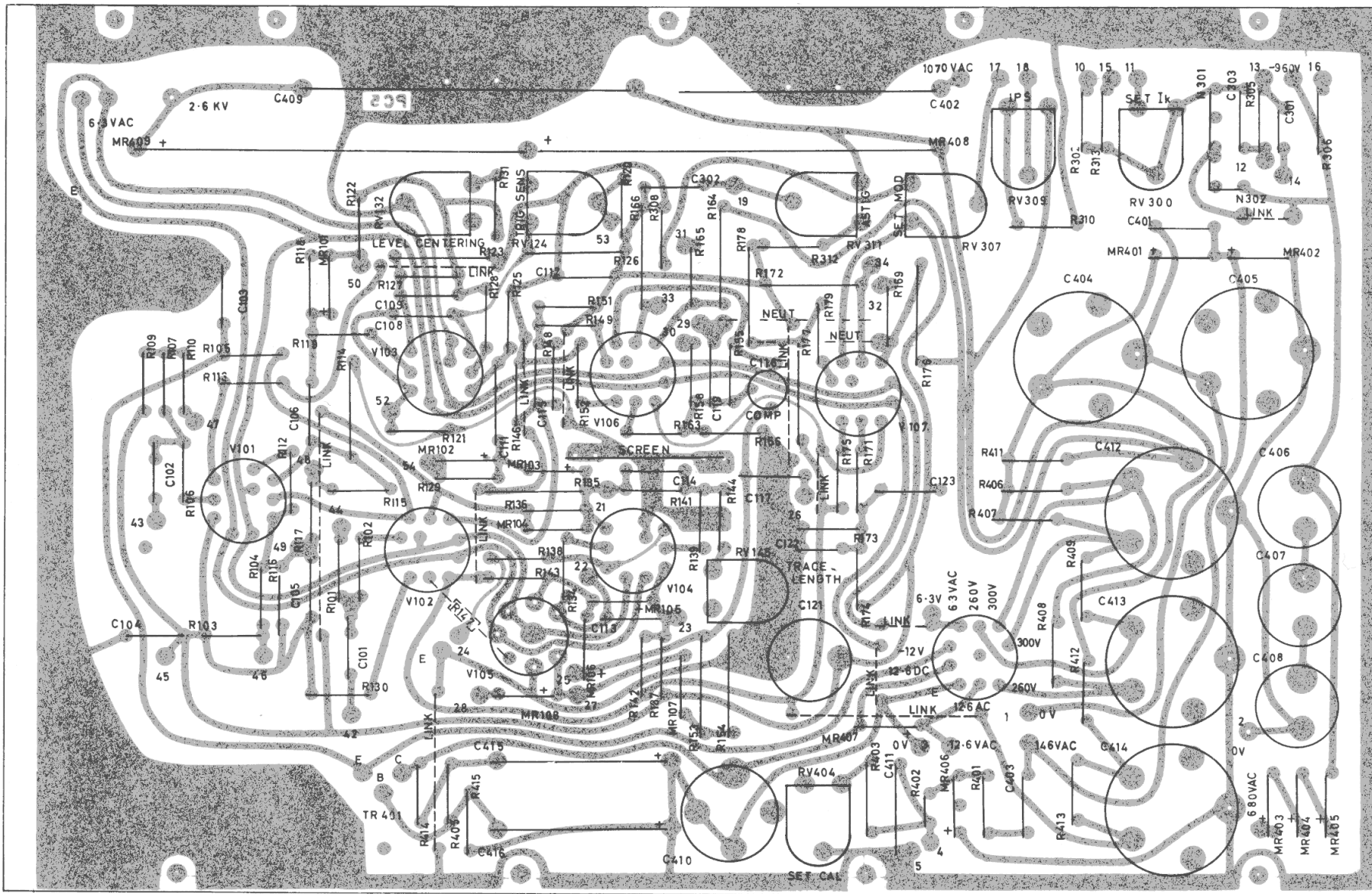

PLATE 3. TRIGGER, TIME BASE, CRT and H.T. PRINTED CIRCUIT BOARD.